

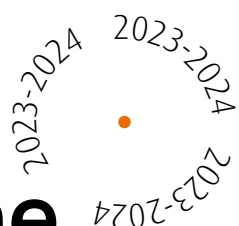

RMBPROJECTS

**Automne  
Hiver**  
*Autumn  
Winter*





# Légende

## Legend

	Largeur totale <i>Total width</i>		Diamètre du plateau <i>Table top diameter</i>
	Profondeur totale <i>Total depth</i>		Hauteur réglable de la table <i>Adjustable table height</i>
	Hauteur totale <i>Total height</i>		Dimensions plateau min. ou max. conseillées <i>Min. or max. advised table top sizes</i>
	Hauteur assise <i>Seat height</i>		Conditionnement <i>Packaging</i>
	Hauteur d'accoudoir (centre) <i>Armrest height (centre)</i>		Mat-Faible réflectivité <i>Low light reflectivity</i>
	Poids Net <i>Net weight</i>		Anti-traces de doigts <i>Fingerprint-proof</i>
	Empilable <i>Stackable</i>		Hydrofuge <i>Water repellent</i>
	Diamètre de l'assise <i>Seat diameter</i>		Polyester recyclé <i>Recycled polyester</i>
	Hauteur du tabouret (Bar)Stool height		Proclean
	Longueur de la croix <i>Cross length</i>		Classement non-feu (+N° Norme) <i>Fire resistant rating (+N° Norm)</i>
	Longueur X largeur de la base <i>Base length x width</i>		Nettoyage facile <i>Easy clean</i>
	Hauteur du piètement <i>Table base height</i>		Lavage Facile <i>Easy care</i>
	Diamètre de la base <i>Base diameter</i>		Forest Stewardship Council <i>"Gestion responsable des forêts"</i>
	Longueur de la base <i>Base length</i>		Produit certifié - Faibles émissions de substances chimiques - UL 2818 <i>Product certified for low chemical emissions - UL 2818</i>
	Longueur X largeur du plateau <i>Table top length x width</i>		ISO 4892-3:2016 Résistance aux UV <i>ISO 4892-3:2016 UV resistant</i>
	Longueur X largeur de la base <i>Base length x width</i>		Test de longévité sur le système pliant : 2000 cycles <i>Folding mechanism durability test : 2000 cycles</i>
	Hauteur de la table <i>Table height</i>		ISO 9227:2017 Utilisation Bord de mer <i>Standard ISO 9227:2017 - Seaside use</i>
	Dimensions de la table pliée <i>Folded table measurements</i>		Usage extérieur <i>Outdoor use</i>
	Pliable & encastrable <i>Foldable &amp; stackable</i>		Usage intérieur uniquement <i>Indoor use only</i>
	Table Pliante <i>Folding Table</i>		À monter <i>To be assembled</i>
			Numéro de l'échantillon <i>Sample reference number</i>

## Intérieur - *Indoor*

08-127 Assises  
*Seats*

128-133 Tables Basses  
*Low tables*

134-145 Piètements  
*Table Bases*

146-153 Plateaux  
*Table Tops*

154-157 Meubles  
*Furniture*

## Extérieur - *Outdoor*

160-241 Assises  
*Seats*

242-249 Tables  
*Tables*

250-253 Parasol  
*Parasol*

254-263 Piètements  
*Table Bases*

264-271 Plateaux  
*Table Tops*

## Réception - *Catering*

274-279 Assises  
*Seats*

280-283 Tables  
*Tables*

## Divers - *Miscellaneous Infos*

286-297 Informations techniques  
*Technical information*

298-301 Correspondance Pieds/Plateaux  
*Matching table tops and bases*

302 Pièces détachées  
*Spare parts*

304-312 Index  
*Index*







Intérieur - Indoor

# Simone

New

Chaise - Chair



Terra 59  
Terra 59

Vert 39  
Green 39

Gris Clair 83  
Light Grey 83



i p290

DAVIS  
Aragon

ABRASION TEST  
45.000-60.000

EN 1021-1  
part 1



Structure en métal noir - Épaisseur tube 1,8mm - Diamètre tube 16mm - Assise et dossier garnis de tissu ARAGON.  
Black metal frame - Tube thickness 1.8mm - Tube diameter 16mm - Upholstered seat and back with fabric ARAGON.

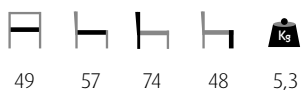

49 57 74 48 5,3





# Simone



# René

New

Fauteuil - Armchair



Terra 59  
Terra 59

Vert 39  
Green 39

Gris Clair 83  
Light Grey 83



i p290

DAVIS  
Aragon

ABRASION TEST  
45.000-60.000

EN 1021-1  
part 1



Structure en métal noir - Épaisseur tube 1,8mm - Diamètre tube 16mm - Assise et dossier garnis de tissu ARAGON.  
Black metal frame - Tube thickness 1.8mm - Tube diameter 16mm - Upholstered seat and back with fabric ARAGON.

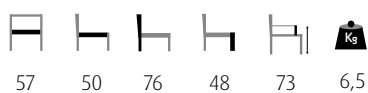



# René

# Auguste

New

Tabouret - Barstool



Terra 59  
Terra 59

Vert 39  
Green 39

Gris Clair 83  
Light Grey 83



i p290

DAVIS  
Aragon

ABRASION TEST  
45.000-60.000

EN 1021-1  
part 1



Structure en métal noir - Épaisseur tube 2mm - Diamètre tube 19mm - Assise et dossier garnis de tissu ARAGON.  
Black metal frame - Tube thickness 2mm - Tube diameter 19mm - Upholstered seat and back with fabric ARAGON.

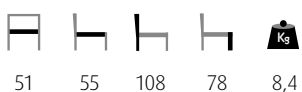

51 55 108 78 8,4





# Auguste

# Mélina

New

Chaise - Chair



Gris 18  
Grey 18



 p290

**DAVIS**  
Gava

**ABRASION TEST**  
90.000-100.000

  
EN 1021-1  
BS 5852  
part 1

  
WATER  
REPELLENT

  
RECYCLED  
POLYESTER

Structure en métal noir - Épaisseur tube 1,5mm - Diamètre tube 19mm - Assise et dossier garnis de tissu GAVA.  
Black metal frame - Tube thickness 1,5mm - Tube diameter 19mm - Upholstered seat and back with fabric GAVA.

      
55 58 75 48 5,4





# Méline

# Sandra

New

Tabouret - Barstool



Gris 18  
Grey 18



 p290

**DAVIS**  
Gava

**ABRASION TEST**  
90.000-100.000

  
EN 1021-1  
BS 5852  
part 1

  
WATER  
REPELLENT

  
RECYCLED  
POLYESTER

Structure en métal noir - Épaisseur tube 1,5mm - Diamètre tube 19mm - Assise et dossier garnis de tissu GAVA.  
Black metal frame - Tube thickness 1,5mm - Tube diameter 19mm - Upholstered seat and back with fabric GAVA.

      
53 56 104 79 6





# Sandra



# Noëlia

New

Chaise - Chair



Gris 10/Noir  
Grey 10/Black



 p292

**ABRASION TEST**  
30.000

**fab**  
Brego

Structure en métal noir - Épaisseur tube: dossier 1,8mm/pieds 2,5mm - Diamètre tube 16mm - Assise garnie de tissu BREGO, dossier en contre-plaqué, garnis en PVC imitation cannage naturel.

Black metal frame - Tube thickness: back 1.8mm/legs 2.5mm - Diameter tube 16mm - Seat upholstered in BREGO fabric, plywood backrest with PVC imitation natural caning.

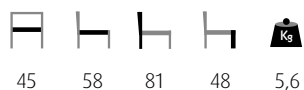

45 58 81 48 5,6





# Noëlia

# Zoé

New

Chaise - Chair

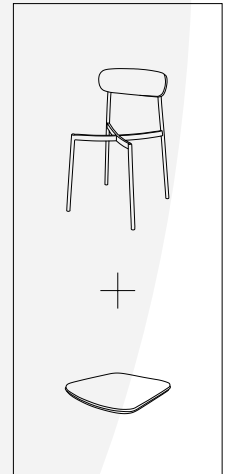

STRUCTURE - FRAME

Noir & Bois Naturel  
Black & Natural Wood



Blanc & Bois Naturel  
White & Natural Wood

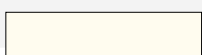

ASSISE - SEAT

Gris Brun 056  
Grey Brown 056



Olive 144  
Olive 144



Orange 106  
Orange 106



Beige 032  
Beige 032



p292

Miss

**ABRASION TEST**  
>40.000

Structure en métal - Épaisseur tube 2mm - Diamètre tube 19mm - Assise en contre-plaqué, garnie de tissu MISS, dossier en contre-plaqué.

Metal frame - Tube thickness 2mm - Tube diameter 19mm - Plywood seat upholstered in MISS fabric, plywood back.



47 48 79 48 6





# Zoé

# Ralph

New

Tabouret - Barstool

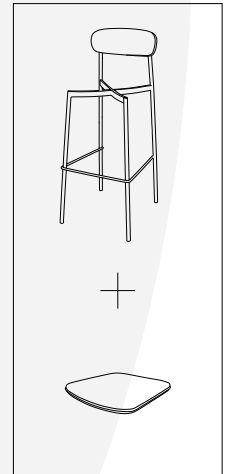

STRUCTURE - FRAME

Noir & Bois Naturel  
Black & Natural Wood



Blanc & Bois Naturel  
White & Natural Wood

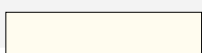

ASSISE - SEAT

Gris Brun 056  
Grey Brown 056



Olive 144  
Olive 144



Orange 106  
Orange 106



Beige 032  
Beige 032



p292

Miss

**ABRASION TEST**  
>40.000

Structure en métal - Épaisseur tube 2mm - Diamètre tube 19mm - Assise en contre-plaqué, garnie de tissu MISS, dossier en contre-plaqué.

Metal frame - Tube thickness 2mm - Tube diameter 19mm - Plywood seat upholstered in MISS fabric, plywood back.



42 48 106 78 6,8





# Ralph

# Paulette

New

Chaufeuse - Lounge chair



Grace Tempete 77  
Cloud Orage 97  
Grace Tempest 77  
Cloud Storm 97

Grace Corde 16  
Cloud Pierre 87  
Grace Rope 16  
Cloud Stone 87



p291

**DAVIS**  
Grace  
Cloud

**ABRASION TEST**  
Cloud 90-100.000  
Grace 60-70.000

EN 1021-1  
BS 5852  
part 1

RECYCLED  
POLYESTER  
Grace

EASY  
CLEAN

Structure en hêtre teinté noir - Assise et dos garnis en bi-tissus.  
Beech frame black stained - Bi-fabric upholstered seat and back.

70 72 77,5 43 14.2





# Paulette



# Colette

Chaise - Chair



Grace Tempete 77  
 Cloud Orage 97  
 Grace Tempest 77  
 Cloud Storm 97

Grace Corde 16  
 Cloud Pierre 87  
 Grace Rope 16  
 Cloud Stone 87

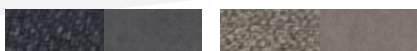

 p291

**DAVIS**  
 Grace  
 Cloud

**ABRASION TEST**  
 Cloud 90-100.000  
 Grace 60-70.000

  
 EN 1021-1  
 BS 5852  
 part 1

  
 RECYCLED  
 POLYESTER  
 Grace

  
 EASY  
 CLEAN

Structure en hêtre teinté noir - Assise et dos garnis en bi-tissus.  
 Beech frame black stained - Bi-fabric upholstered seat and back.





# Colette

# Adèle

Chaise - Chair



Grace Tempete 77  
Cloud Orage 97  
Grace Tempest 77  
Cloud Storm 97

Grace Corde 16  
Cloud Pierre 87  
Grace Rope 16  
Cloud Stone 87

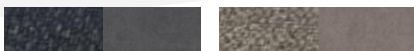

 p291

**DAVIS**  
Grace  
Cloud

**ABRASION TEST**  
Cloud 90-100.000  
Grace 60-70.000

  
EN 1021-1  
BS 5852  
part 1

  
RECYCLED  
POLYESTER  
Grace

  
EASY  
CLEAN

Structure en hêtre teinté noir - Assise et dos garnis en bi-tissus.  
Beech frame black stained - Bi-fabric upholstered seat and back.

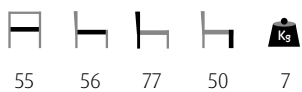



# Adèle

# Victoire Bst

Tabouret - *Barstool*



Grace Tempete 77  
Cloud Orage 97  
Grace Tempest 77  
Cloud Storm 97

Grace Corde 16  
Cloud Pierre 87  
Grace Rope 16  
Cloud Stone 87



 p291

**DAVIS**  
LABOR  
Grace  
Cloud

**ABRASION TEST**  
Cloud 90-100.000  
Grace 60-70.000

  
EN 1021-1  
BS 5852  
part 1

  
RECYCLED  
POLYESTER  
Grace

  
EASY  
CLEAN

Structure en hêtre teinté noir - Assise et dos garnis en bi-tissus - Repose-pieds en hêtre avec renfort métallique.  
*Beech frame black stained - Bi-fabric upholstered seat and back - Beech footrest with metal reinforcement.*





# Victoire Bst

# Mikka

New

Chaise - Chair



Cuoio  
Cuoio

Anthracite  
Anthracite



 p292





 **elastron**  
COLORADO

**ABRASION TEST**  
100.000

  
EN 1021-1  
BS 5852  
part 1



Structure en métal noir - Épaisseur tube 1,5mm - Diamètre tube 32mm - Assise et dossier garnis de similicuir PU COLORADO.  
Black metal frame - Tube thickness 1.5mm - Tube diameter 32mm - Seat and back upholstered in PU COLORADO imitation leather.

      
56 60 81 48 7,4





# Mikka



# Olaf

New

Fauteuil - Armchair



Cuoio  
Cuoio

Anthracite  
Anthracite



p292

**elastron**  
COLORADO

**ABRASION TEST**  
100.000

EN 1021-1  
BS 5852  
part 1



Structure en métal noir - Épaisseur tube 1,5mm - Diamètre tube 32mm - Assise et dossier garnis de similicuir PU COLORADO.  
Black metal frame - Tube thickness 1.5mm - Tube diameter 32mm - Seat and back upholstered in PU COLORADO imitation leather.

**Kg**  
57 59 87 48 66 6,8





# Olaf

# Jacob

New

Chaise - Chair



Cuoio  
Cuoio

Anthracite  
Anthracite



 p292

 **elastron**  
COLORADO

**ABRASION TEST**  
100.000

  
EN 1021-1  
BS 5852  
part 1



Structure en métal noir - Épaisseur tube 1,5mm - Tube 15x30mm - Assise et dossier garnis de similicuir PU COLORADO.  
Black metal frame - Tube thickness 1.5mm - Tube 15x30mm - Seat and back upholstered in PU COLORADO imitation leather.

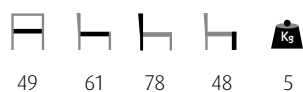



# Jacob

# Kyle

New

Tabouret - Barstool



Cuoio  
Cuoio

Anthracite  
Anthracite



p292

**elastron**  
COLORADO

**ABRASION TEST**  
100.000

EN 1021-1  
BS 5852  
part 1



Structure en métal noir - Épaisseur tube 1,5mm - Tube 19x30mm - Assise et dossier garnis de similicuir PU COLORADO.  
Black metal frame - Tube thickness 1.5mm - Tube 19x30mm - Seat and back upholstered in PU COLORADO imitation leather.

46 53 106 78 6,1





# Kyle

# Wendy

New

Banquette - Bench



Connecteur amovible inclus  
Removable connector included



Cuoio  
Cuoio

Anthracite  
Anthracite



p292

**COLORADO**

**ABRASION TEST**  
100.000

EN 1021-1  
BS 5852  
part 1



Structure en métal noir - Épaisseur tube 1,5mm - Tube 30x30mm - Assise et dossier garnis de similicuir PU COLORADO.  
Black metal frame - Tube thickness 1.5mm - Tube 30x30mm - Seat and back upholstered in PU COLORADO imitation leather.

120 60 94 48 30





# Wendy



# Maurice

Chaise - Chair



Cognac  
Cognac

Anthracite  
Anthracite

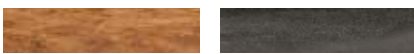

EN 1021-1

Structure métallique noire - Épaisseur tube 1,5mm - Diamètre tube 28mm - Assise et dos garnis en similicuir PU.  
Black metal frame - Tube thickness 1.5mm - Tube diameter 28mm - Seat and back upholstered with PU faux-leather.

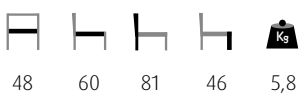



# Maurice

# Maurice Bst

Tabouret - Barstool



H65

Maurice Bst H65



H79

Maurice Bst H79

Cognac  
Cognac



Anthracite  
Anthracite



EN 1021-1

Structure métallique noire - Épaisseur tube 1,5mm - Diamètre tube 28mm - Assise et dos garnis en similicuir PU.  
Black metal frame - Tube thickness 1.5mm - Tube diameter 28mm - Seat and back upholstered with PU faux-leather.



Maurice Bst H65



Maurice Bst H79





# Maurice Bst

# College

New

Chaise - Chair



Teinte Brun «Vintage»  
«Vintage Brown» Stain



Structure en métal finition industrielle, vernis brillant - Épaisseur tube 1,5mm - Diamètre tube 25mm - Assise et dossier en contre-plaqué.

*Metal frame, industrial finish, glossy varnish - Tube thickness 1.5mm - Tube diameter 25mm - Seat and back in plywood.*

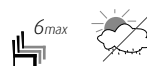
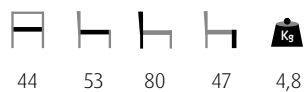



# College

# Montreal

New

Fauteuil - Armchair



Marron Vintage  
Vintage Brown



Structure en métal noir - Épaisseur tube 40x20x1,2mm - Assise et dossier garnis de similicuir PU.  
Black metal frame - Tube thickness 40x20x1.2mm - Seat and back upholstered with PU faux-leather.



52 55 77 46 68 7,5





# Montreal



# Stanley

Chaise - Chair



Marron Vintage  
Marron Vintage

Structure métallique noire - Épaisseur tube 1,5mm - Diamètre tube 19mm - Assise et dos garnis en similicuir PU.  
Black metal frame - Tube thickness 1.5mm - Tube diameter 19mm - Seat and back upholstered with PU faux-leather.

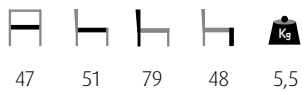



# Stanley

# Stanley Bst

Tabouret - Barstool



Marron Vintage  
Marron Vintage

Structure métallique noire - Épaisseur tube 1,5mm - Diamètre tube 19mm - Assise et dos garnis en similicuir PU.  
Black metal frame - Tube thickness 1.5mm - Tube diameter 19mm - Seat and back upholstered with PU faux-leather.





# Stanley Bst

# Brixton

Fauteuil - *Armchair*



Marron Vintage  
*Vintage Brown*



Structure métallique noire - Accoudoirs en bois - Épaisseur tube 2mm - Diamètre tube 28mm - Assise et dos garnis en similicuir PU.

*Black metal frame - Wooden armrests - Tube thickness 2mm - Tube diameter 28mm - Seat and back upholstered with PU faux-leather.*

65	78	91	44	64,5	18,5	





# Brixton

# Soho

Chaise - Chair



Cognac Vintage  
Cognac Vintage

Structure métallique noire - Épaisseur tube 1,5mm - Diamètre tube 30mm - Assise et dos garnis en similicuir PU.  
Black metal frame - Tube thickness 1.5mm - Tube diameter 30mm - Seat and back upholstered with PU faux-leather.

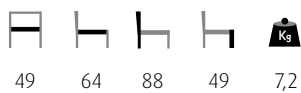



# Soho



# Alex

Stock  
Limité  
Limited  
Stock

Chaise - Chair



Noir  
Black

Structure métallique noire - Épaisseur tube 1,5mm - Diamètre tube 22mm - Assise et dos garnis en similicuir PU.  
Black metal frame - Tube thickness 1.5mm - Tube diameter 22mm - Seat and back upholstered with PU faux-leather.

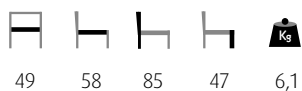



# Alex

# Barossa

Stock  
Limité  
Limited  
Stock

Chaise - Chair



Cognac  
Cognac



 p293

Structure métallique noire - Épaisseur tube 1,2mm - Diamètre tube 32mm - Assise et dos garnis en similicuir PU VICTORY.  
Black metal frame - Tube thickness 1.2mm - Tube diameter 32mm - Seat and back upholstered with VICTORY PU faux-leather.

      
48 65 87 49 6,3





# Barossa

# Peak

Stock  
Limité  
Limited  
Stock

Chaise - Chair



Cognac  
Cognac



 p294

Structure métallique noire - Épaisseur tube 1,2mm - Diamètre tube 32mm - Assise et dos garnis de tissu SOFTYL.  
Black metal frame - Tube thickness 1.2mm - Tube diameter 32mm - Seat and back upholstered with SOFTYL fabric.

      
48 65 88 49 6,3





# Peak

# Condor

Stock  
Limité  
Limited  
Stock

Fauteuil - *Armchair*



Cognac  
*Cognac*

Anthracite  
*Anthracite*



 p294

Structure métallique noire (en une pièce) - Épaisseur tube 1,2mm - Tube 20x20mm - Assise et dos garnis de tissu SOFTYL.  
*Black metal frame (in one piece) - Tube thickness 1,2mm - Tube 20x20mm - Seat and back upholstered with SOFTYL fabric.*

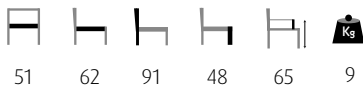



# Condor



# Pickup

Stock  
Limité  
Limited  
Stock

Chaise - Chair



Cognac  
Cognac

Anthracite  
Anthracite



 p294

Structure métallique noire - Épaisseur tube 1,2mm - Tube 25x25mm - Assise et dos garnis de tissu LUXOR.  
Black metal frame - Tube thickness 1.2mm - Tube 25x25mm - Seat and back upholstered with LUXOR fabric.



48 59 88 48 8





# Pickup

# Splash

Stock  
Limité  
Limited  
Stock

Chaise - Chair



Cognac  
Cognac

Anthracite  
Anthracite



 p294

Structure métallique noire - Épaisseur tube 1,2mm - Tube 25x25mm - Assise et dos garnis de tissu LUXOR.  
Black metal frame - Tube thickness 1.2mm - Tube 25x25mm - Seat and back upholstered with LUXOR fabric.

       
54 64 86 50 7,7





# Splash

# Alicia

Stock  
Limité  
Limited  
Stock

Chaise - Chair







Cognac  
Cognac

Anthracite  
Anthracite



 p294

Structure métallique noire - Épaisseur tube 1,2mm - Tube ovale 50mm - Assise et dos garnis de tissu SOFTYL.  
Black metal frame - Tube thickness 1.2mm - Oval tube 50mm - Seat and back upholstered with SOFTYL fabric.

       
52 63 90 49 7,8





# Alicia

# Capri

Stock  
Limité  
Limited  
Stock

Tabouret H65 - Barstool H65



Cognac  
Cognac



 p294

Structure métallique noire - Épaisseur tube 1,2mm - Diamètre tube 32mm - Assise et dos garnis de tissu SOFTYL.  
Black metal frame - Tube thickness 1.2mm - Tube diameter 32mm - Seat and back upholstered with SOFTYL fabric.

      
49 64 105 65 8,5





# Capri



# Cuba

Fauteuil - *Armchair*



Brun Clair 41  
*Light Brown 41*



 p294

**fab**<sup>®</sup>  
Cortes

**ABRASION TEST**  
35.000

Structure en hêtre teinté Wengé - Assise et dos garnis de tissu Vintage CORTES.  
*Beech frame Wenge stained - Seat and back upholstered with CORTES fabric.*

72 69 70 43 67 16,8



# Cuba

# Cuba Double

Sofa - Sofa



Brun Clair 41  
Light Brown 41









 p294

**fabb**  
Cortes

**ABRASION TEST**  
35.000

Structure en hêtre teinté Wengé - Assise et dos garnis de tissu Vintage CORTES.  
Beech frame Wenge stained - Seat and back upholstered with CORTES fabric.

119 69 70 43 67 22,3



# Cuba Double

# Kate

New

Chaise - Chair

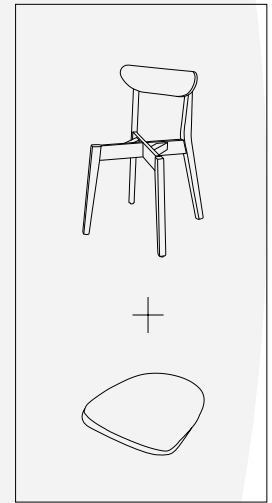

**STRUCTURE - FRAME**

Teinte Chêne Miel  
Honey Oak Stain

Noir  
Black

**ASSISE - SEAT**

Rouille 52  
Rusty 52

Gris 90  
Grey 90

Vert 34  
Green 34

Bleu 75  
Blue 75

p291

**DAVIS**  
Luis

**ABRASION TEST**  
30.000

BS 5852  
part 1  
EN 1021-1

WATER  
REPELLENT

Structure en hêtre teinté - Assise garnie de tissu LUIS - À assembler.  
Stained beech frame - Upholstered seat with LUIS fabric - To be assembled.

44 48 76 49 5,1

Dimension compacte  
Compact size





# Kate

# Budapest

Chaise - Chair

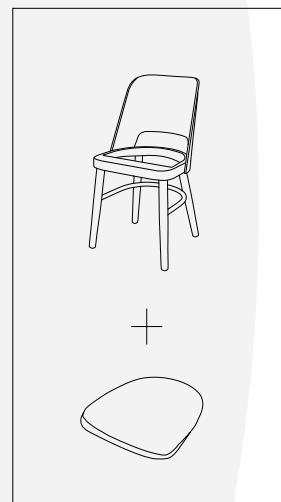

STRUCTURE - FRAME  
Teinte Chêne Miel  
Honey Oak Stain



Bordeaux 5269  
Bordeaux 5269



Cappuccino 5582  
Cappuccino 5582



Olive 9430  
Olive 9430



STRUCTURE - FRAME  
Teinte Wengé  
Wenge Stain



ASSISE - SEAT  
Éléphant 5272  
Elephant 5272



Terra 9244  
Terra 9244



Noir 7006  
Black 7006



p293

TEXTUM  
Lotos

**ABRASION TEST**  
>100.000

**BS 5852**  
part 1

Structure en hêtre - Assise garnie de similicuir PU LOTOS - À assembler.  
Beech frame - Upholstered seat with LOTOS PU faux-leather - To be assembled.

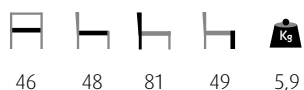

46 48 81 49 5,9





# Budapest



# Budapest Bst

Tabouret - Barstool

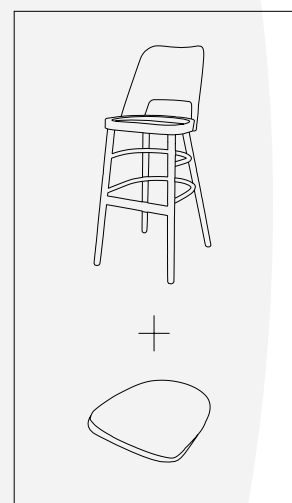

**STRUCTURE - FRAME**

Teinte Chêne Miel  
Honey Oak Stain



Teinte Wengé  
Wenge Stain



**ASSISE - SEAT**

Bordeaux 5269  
Bordeaux 5269



Éléphant 5272  
Elephant 5272



Cappuccino 5582  
Cappuccino 5582



Terra 9244  
Terra 9244

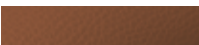

Olive 9430  
Olive 9430

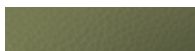

Noir 7006  
Black 7006



 p293

 Lotos

**ABRASION TEST**  
>100.000

  
BS 5852  
part 1

Structure en hêtre - Assise garnie de similicuir PU LOTOS - Repose-pieds en hêtre avec renfort métallique - À assembler.  
Beech frame - Upholstered seat with LOTOS PU faux-leather - Beech footrest with metal - To be assembled.





# Budapest Bst

# Dimitri

Chaise - Chair

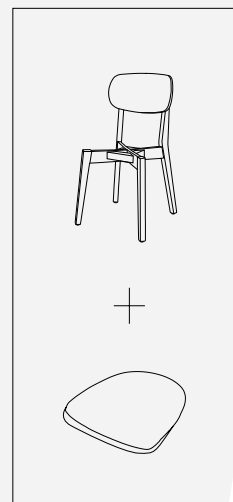

STRUCTURE - FRAME

Teinte Chêne Miel  
Honey Oak Stain



ASSISE - SEAT

Noir 7006  
Black 7006



 p293

 TEXTUM  
Lotos

**ABRASION TEST**  
>100.000

  
BS 5852  
part 1

Structure en hêtre - Assise garnie de similicuir PU LOTOS - À assembler.  
Beech frame - Upholstered seat with LOTOS PU faux-leather - To be assembled.

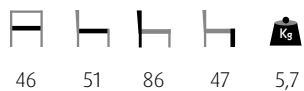



# Dimitri

# Dimitri Bst

Tabouret - Barstool

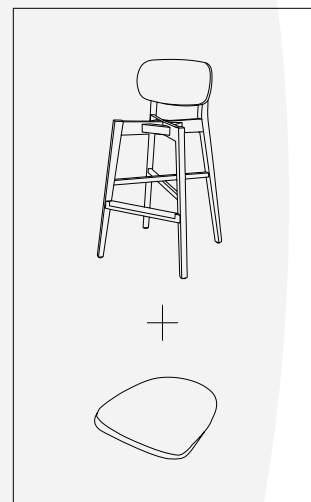

STRUCTURE - FRAME

Teinte Chêne Miel  
Honey Oak Stain



ASSISE - SEAT

Noir 7006  
Black 7006





 p293

 TEXTUM  
Lotos

**ABRASION TEST**  
>100.000

  
BS 5852  
part 1

Structure en hêtre - Assise garnie de similicuir PU LOTOS - Repose-pieds en hêtre avec renfort métallique - À assembler.  
Beech frame - Upholstered seat with LOTOS PU faux-leather - Beech footrest with metal - To be assembled.

      
50 49 102 77 7,4





# Dimitri Bst

# Brooklyn

Chaise - Chair

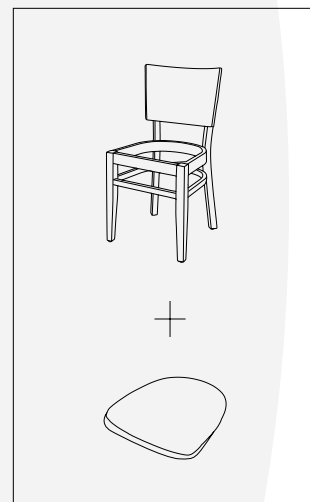

STRUCTURE - FRAME

Teinte Wengé  
Wenge Stain

Bordeaux 5269  
Bordeaux 5269

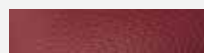

Cappuccino 5582  
Cappuccino 5582



ASSISE - SEAT

Chocolat 9314  
Chocolat 9314



Noir 7006  
Black 7006



p293

TEXTUM  
Lotos

**ABRASION TEST**  
>100.000

**BS 5852**  
part 1

Structure en hêtre teinté - Assise garnie de similicuir PU LOTOS - À assembler.  
Beech frame Wenge stained - Upholstered seat with LOTOS PU faux-leather - To be assembled.

43 53 85 47 8,6





# Brooklyn



# Brooklyn Bst

Tabouret - Barstool

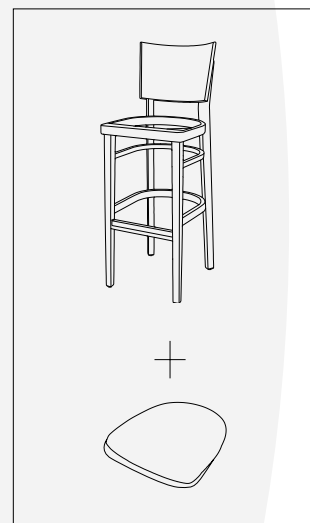

STRUCTURE - FRAME

Teinte Wengé  
Wenge Stain

Bordeaux 5269  
Bordeaux 5269



ASSISE - SEAT

Chocolat 9314  
Chocolat 9314



Cappuccino 5582  
Cappuccino 5582



Noir 7006  
Black 7006



p293

TEXTUM  
Lotos

**ABRASION TEST**  
>100.000

**BS 5852**  
part 1

Structure en hêtre teinté - Assise garnie de similicuir PU LOTOS - Repose-pieds en hêtre avec renfort métallique noir - À assembler.  
Beech frame Wenge stained - Upholstered seat with LOTOS PU faux-leather - Beech footrest with black metal - To be assembled.

**Kg**  
44 53 109 79 10,9





# Brooklyn Bst

# Pub

Chaise - Chair

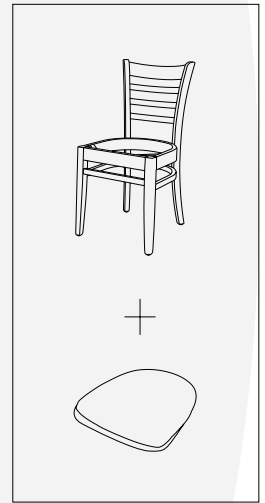

STRUCTURE - FRAME

Teinte Wengé  
Wenge Stain

Bordeaux 5269  
Bordeaux 5269

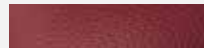

Cappuccino 5582  
Cappuccino 5582



ASSISE - SEAT

Chocolat 9314  
Chocolat 9314



Noir 7006  
Black 7006



p293

TEXTUM  
Lotos

**ABRASION TEST**  
>100.000

**BS 5852**  
part 1

Structure en hêtre teinté - Assise garnie de similicuir PU LOTOS - À assembler.  
Beech frame Wenge stained - Upholstered seat with LOTOS PU faux-leather - To be assembled.





# Pub

# Pub Bst

Tabouret - Barstool

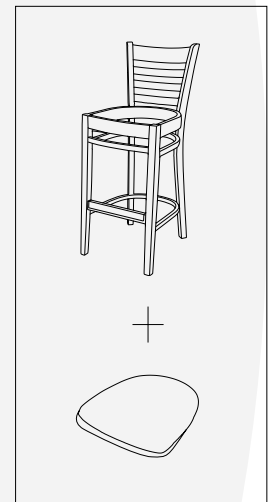

STRUCTURE - FRAME

Teinte Wengé  
Wenge Stain

Bordeaux 5269  
Bordeaux 5269

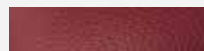

ASSISE - SEAT

Chocolat 9314  
Chocolat 9314



Cappuccino 5582  
Cappuccino 5582



Noir 7006  
Black 7006



p293

TEXTUM  
Lotos

**ABRASION TEST**  
>100.000

**BS 5852**  
part 1

Structure en hêtre teinté - Assise garnie de similicuir PU LOTOS - Repose-pieds en hêtre avec renfort métallique noir - À assembler.  
Beech frame Wenge stained - Upholstered seat with LOTOS PU faux-leather - Beech footrest with black metal - To be assembled.

44 53 109 79 9,3





# Pub Bst

# Sofia

Chaise - Chair



Noir  
Black

Brun Foncé  
Dark Brown

French Patina  
French Patina

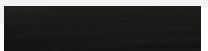

Structure en hêtre teinté .  
Stained beech frame.



46 45 87 47 4





# Sofia



# Sofia Bst

Tabouret - Barstool



Noir  
Black

Brun Foncé  
Dark Brown

French Patina  
French Patina



Structure en hêtre teinté .  
Stained beech frame.



46 45 108 76 5,3





# Sofia Bst

# Maurice

Chaise - Chair



Burgundy 69  
Burgundy 69



Petrol 76  
Petrol 76



Olive 38  
Olive 38



 p291

**DAVIS**  
Monolith

**ABRASION TEST**  
90.000-100.000

  
EN 1021-1  
BS 5852  
part 1



Structure métallique noire - Épaisseur tube 1,5mm - Diamètre tube 25mm - Assise et dossier garnis de velours MONOLITH Passepoil noir.

Black metal frame - Tube thickness 1.5mm - Tube diameter 25mm - Seat and back upholstered with MONOLITH velvet - Black piping.

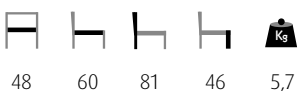



# Maurice

# Maurice Bst

Tabouret - Barstool



Burgundy 69  
Burgundy 69

Petrol 76  
Petrol 76

Olive 38  
Olive 38



 p291

**DAVIS**  
Monolith

**ABRASION TEST**  
90.000-100.000

  
EN 1021-1  
BS 5852  
part 1

  
WATER  
REPELLENT

Structure métallique noire - Épaisseur tube 1,5mm - Diamètre tube 22mm - Assise et dossier garnis de velours MONOLITH Passepoil noir.

Black metal frame - Tube thickness 1.5mm - Tube diameter 22mm - Seat and back upholstered with MONOLITH velvet - Black piping.





# Maurice Bst

# Emile

Chaise - Chair



Anthracite 92  
Anthracite 92

Petrol 76  
Petrol 76

Olive 38  
Olive 38

Gold 48  
Gold 48

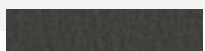

 p291

**DAVIS**  
Monolith

**ABRASION TEST**  
90.000-100.000

  
EN 1021-1  
BS 5852  
part 1

  
WATER  
REPELLENT

Structure en hêtre teinté noir - Assise et dossier garnis de velours MONOLITH.  
Beech frame black stained - Seat and back upholstered with MONOLITH velvet.



49 55 81 49 6





# Emile



# Alfonse

Fauteuil - *Armchair*



Anthracite 92  
Anthracite 92

Petrol 76  
Petrol 76

Olive 38  
Olive 38

Gold 48  
Gold 48

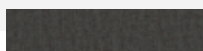

p291

**DAVIS**  
Monolith

**ABRASION TEST**  
90.000-100.000

EN 1021-1  
BS 5852  
part 1

WATER  
REPELLENT

Structure en hêtre teinté noir - Assise et dossier garnis de velours MONOLITH.  
*Beech frame black stained - Seat and back upholstered with MONOLITH velvet.*





# Alfonse

# Oscar Bst

Tabouret - Barstool



Anthracite 92  
Anthracite 92

Petrol 76  
Petrol 76

Olive 38  
Olive 38

Gold 48  
Gold 48

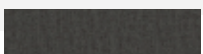

**DAVIS**  
MONOLITH

**ABRASION TEST**  
90.000-100.000

EN 1021-1  
BS 5852  
part 1



Structure en hêtre teinté noir - Assise et dos garnis de velours MONOLITH - Repose-pieds en hêtre avec renfort métallique.  
Beech frame black stained - Seat and back upholstered with MONOLITH velvet - Beech footrest with metal reinforcement.



52 57 105 77 9





# Oscar Bst

# Lautrec S

Chaufeuse - Lounge Chair



Anthracite 92  
Anthracite 92

Petrol 76  
Petrol 76

Olive 38  
Olive 38

Gold 48  
Gold 48

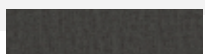

p291

**DAVIS**  
Monolith

**ABRASION TEST**  
90.000-100.000

EN 1021-1  
BS 5852  
part 1

**FSC**

**WATER  
REPELLENT**

Structure en hêtre teinté noir - Assise et dossier garnis de velours MONOLITH.  
Beech frame black stained - Seat and back upholstered with MONOLITH velvet.

64 70 76 43 10,4





# Lautrec S

# Arnold

Fauteuil - *Armchair*



Anthracite 92  
Anthracite 92

Petrol 76  
Petrol 76

Gold 48  
Gold 48



 p291

**DAVIS**  
Monolith

**ABRASION TEST**  
90.000-100.000

  
EN 1021-1  
BS 5852  
part 1



Structure en hêtre - Pieds métalliques noirs - Assise et dossier garnis de velours MONOLITH.  
*Beech frame - Black metal legs - Seat and back upholstered with MONOLITH velvet.*



78 84 83 49 64 27,5





# Arnold



# Willy

Fauteuil - *Armchair*



Anthracite 92  
Anthracite 92

Petrol 76  
Petrol 76

Gold 48  
Gold 48



 p291

**DAVIS**  
Monolith

**ABRASION TEST**  
90.000-100.000

  
EN 1021-1  
BS 5852  
part 1

  
WATER  
REPELLENT

Structure en hêtre - Pieds métalliques noirs - Assise et dossier garnis de velours MONOLITH.  
*Beech frame - Black metal legs - Seat and back upholstered with MONOLITH velvet.*

104   84   83   49   64   39





# Willy

# Floriane II

New

Chaise - Chair



Taupe 926  
Taupe 926

Chocolat 928  
Chocolate 928

Noir 9100  
Black 9100



 p293

Structure en hêtre teinté Wengé- Assise et dossier garnis de similicuir PU.  
Beech frame Wenge stained - Seat and back upholstered with PU faux-leather.





# Floriane II

# Floriane Bst II

New

Tabouret - Barstool



Taupe 926  
Taupe 926

Chocolat 928  
Chocolate 928

Noir 9100  
Black 9100



 p293

Structure en hêtre teinté Wengé - Assise et dossier garnis de similicuir PU - Repose-pieds en métal.  
Beech frame Wenge stained - Seat and back upholstered with PU faux-leather - Metal footrest.

  
45 54 111 78 8,5





# Floriane Bst II

# Lena

Stock  
Limité  
Limited  
Stock

Chaise - Chair



Brun Clair 9811  
Light Brown 9811

Gris Clair 9502  
Light Grey 9502

Anthracite 7006  
Anthracite 7006



i p292  
p295

TEXTUM  
Ezra

ABRASION TEST  
>100000



PROCLEAN

Structure en hêtre teinté Wengé - Assise et dos garnis de tissu EZRA Proclean.  
Beech frame wenge stained - Seat and back upholstered with EZRA Proclean fabric.

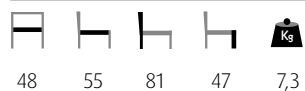



# Lena



# Madison

Stock  
Limité  
Limited  
Stock

Fauteuil - *Armchair*



Rouille 9244  
*Rusty 9244*

Brun Clair 9811  
*Light Brown 9811*

Gris Clair 9502  
*Light Grey 9502*

Anthracite 7006  
*Anthracite 7006*



i p292  
p295

TEXTUM  
Ezra

ABRASION TEST  
>100000



Structure en hêtre teinté Wengé - Assise et dos garnis de tissu EZRA Proclean.  
*Beech frame wenge stained - Seat and back upholstered with EZRA Proclean fabric.*



58 59 81 49 68 8





# Madison

# Clinton

Chaise - Chair



Naturel & Éléphant 5272    Wengé & Noir 7006    Wengé & Pepper 5271  
Natural & Elephant 5272    Wenge & Black 7006    Wenge & Pepper 5271



p293



**ABRASION TEST**  
>100000

  
BS 5852  
part 1



Structure en hêtre teinté - Assise et dos garnis de similicuir PU LOTOS.  
Stained beech frame - Seat and back upholstered with LOTOS PU faux-leather.

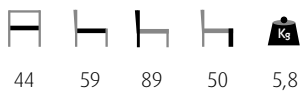



# Clinton

# Clinton Bst

Tabouret - Barstool



Naturel & Éléphant 5272    Wengé & Noir 7006    Wengé & Pepper 5271  
Natural & Elephant 5272    Wenge & Black 7006    Wenge & Pepper 5271



 p293

 **TEXTUM**  
Lotos

**ABRASION TEST**  
>100000

  
BS 5852  
part 1

  
FSC

Structure en hêtre teinté - Assise et dossier garnis de similicuir PU LOTOS - Repose-pieds en métal.  
Stained beech frame - Seat and back upholstered with LOTOS PU faux-leather - Metal footrest.



36    44    100    81    7





# Clinton Bst

# Maryne

New

Table - Table



Marbre noir  
Black marble



Lot de 2 tables - Structure métallique noire - Épaisseur tube 1,5mm - Diamètre tube 25mm - Plateau Mélaminé.  
Set of 2 tables - Black metal frame - Tube thickness 1.5mm - Tube diameter 25mm - Melamine top.



Grande/Big A: 90 / B: 80  
Petite/Small A: 69 / B: 62



Grande/Big: 37  
Petite/Small: 30



Grande/Big: 8,3  
Petite/Small: 5,3





# Maryne



# Jolyne

New

Table - Table



Noir  
Black

Mango  
Mango



Structure métallique noire - Epaisseur de tube 1,5mm - Tube 15x60mm - Plateau Mélaminé - Patins réglables.  
Black metal frame - Tube thickness 1.5mm - Tube 15x60mm - Melamine top - Adjustable footplugs.

    
60 42 9,5





# Jolyne

# Ellen

Table - Table



Naturel  
*Natural*



Structure métallique noire - Épaisseur tube 1,2mm - Tube 60x15mm - Plateau Mélaminé - Patins réglables.  
*Black metal frame - Tube thickness 1.2mm - Tube 60x15mm - Melamine top - Adjustable footplugs.*

    
60 43 11,7





# Ellen

# Factory

Pied de table - *Table base*

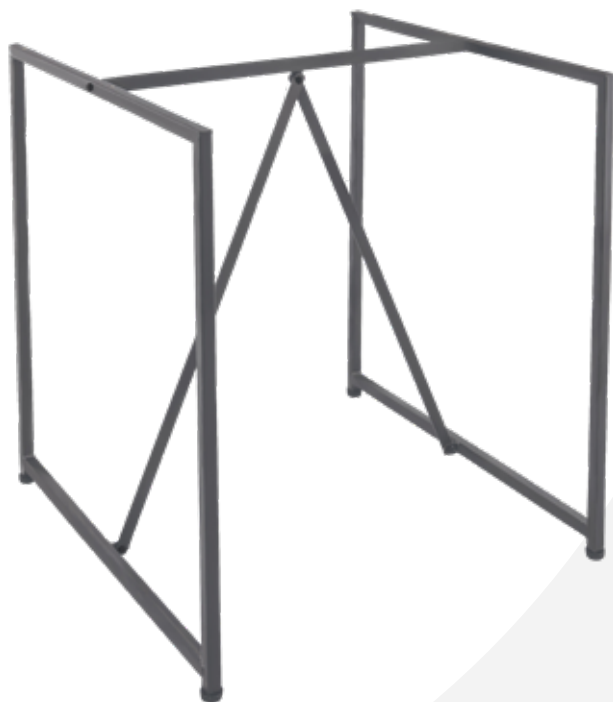

Gun Métal  
*Gun Metal*

Structure métallique - Tube 20x20mm - Épaisseur 2mm - Vérins réglables.  
*Metal frame - Tube size 20x20mm - Tube thickness 2mm - Adjustable plugs.*

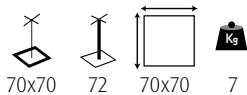

70x70 72 70x70 7



# Retro

Pied de table - *Table base*



Retro Small



Retro Large

Noir  
Black



Fonte d'acier - Epoxy noir - Vérins de réglage.  
Cast iron - Powder coated in black - Adjustable feet.



S 15

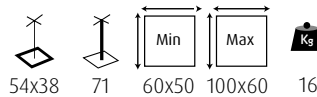

54x38

71

Min

Max

Kg

16

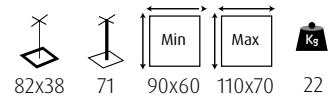

82x38

71

Min

Max

Kg

22

Retro Small

Retro Double

# Bistrot

Pied de table - *Table base*



Bistrot 3 H43



Bistrot 3

Noir  
Black

Fonte d'acier - Epoxy noir - Vérins de réglage. \*  
Cast iron - Powder coated in black - Adjustable feet. \*



S 15

⚠ \*Ces articles peuvent rouiller en utilisation extérieure.  
\*This item may rust when used outdoor.

Bistrot 3 H43

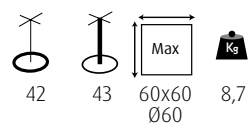

Bistrot 3

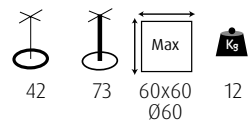

# Bistrot

Pied de table - *Table base*



Bistrot 4



Bistrot 3 Bar

Noir  
Black

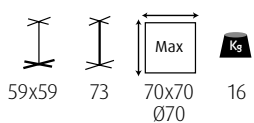

Bistrot 4

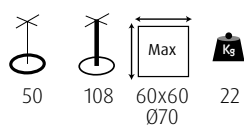

Bistrot 3 Bar

Fonte d'acier - Epoxy noir - Vérins de réglage.\*  
Cast iron - Powder coated in black - Adjustable feet.\*



S 15

\*Ces articles peuvent rouiller en utilisation extérieure. ⚠️  
\*This item may rust when used outdoor.



# Prato

Pied de table - Table base



Prato 16



Prato 19



Prato 30

Noir  
Black

Fonte d'acier - Epoxy noir - Vérins de réglage.  
Cast iron - Powder coated in black - Adjustable feet.



S14

Prato 16

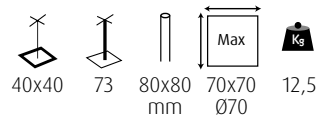

Prato 19

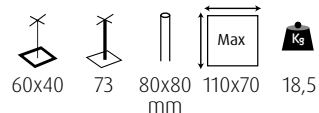

Prato 30

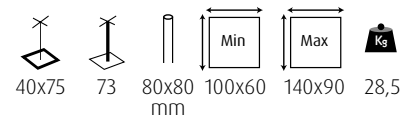

# Prato

Pied de table - *Table base*



Prato 16 Bar



Prato 30 Bar

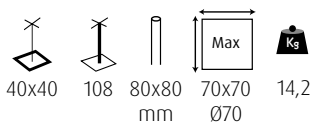

Prato 16 Bar

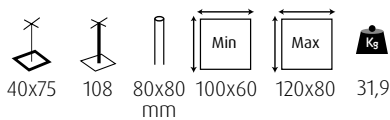

Prato 30 Bar

Noir  
Black

Fonte d'acier - Epoxy noir - Vérins de réglage.  
Cast iron - Powder coated in black - Adjustable feet.



S14

# Prato

Pied de table - Table base



Prato 15



Prato 20

Noir  
Black

Fonte d'acier - Epoxy noir - Vérins de réglage.  
Cast iron - Powder coated in black - Adjustable feet.



S14

Prato 15



40



73



Ø76  
mm



Max  
60x60  
Ø70



10,9

Prato 20



50



73



Ø76  
mm



Max  
80x80  
Ø100



17,4

# Prato

Pied de table - *Table base*



Prato 15 Bar



Prato 70

Noir  
Black

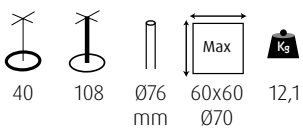

Prato 15 Bar

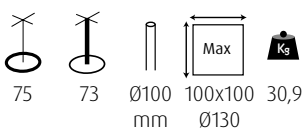

Prato 70

Fonte d'acier - Epoxy noir - Vérins de réglage.  
Cast iron - Powder coated in black - Adjustable feet.



S14

# Rome

Pied de table - *Table base*



Rome 05



Rome 06



Rome 05 Bar

Noir  
Black



Fonte d'acier - Epoxy noir - Vérins de réglage.  
Cast iron - Powder coated in black - Adjustable feet.



S15

Rome 05					
Rome 06					
Rome 05 Bar					

# Rome

Pied de table - Table base



Rome 12



Rome 13



Rome 12 Bar

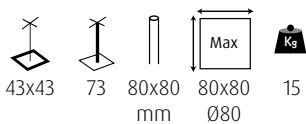

Rome 12

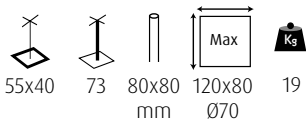

Rome 13

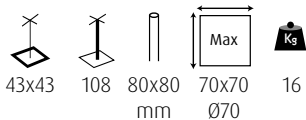

Rome 12 Bar

Noir  
Black



Fonte d'acier - Epoxy noir - Vérins de réglage.  
Cast iron - Powder coated in black - Adjustable feet.



S15

# Sydney

Pied de table - *Table base*



Sydney 4



Sydney Double



Noir

Black

Fonte d'acier - Epoxy noir - Vérins de réglage.  
Cast iron - Powder coated in black - Adjustable feet



S15

Sydney 4



56x56



73

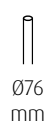

Ø76  
mm



Max  
70x70  
Ø70



8,4

Sydney Double



56



73

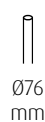

Ø76  
mm



Max  
120x80



13

# Sydney

Pied de table - *Table base*



Sydney 4 Bar

Noir  
Black



Fonte d'acier - Epoxy noir - Vérins de réglage.  
Cast iron - Powder coated in black - Adjustable feet.



S15

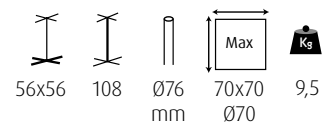

56x56 108 Ø76 mm 70x70 Ø70 9,5

Sydney 4 Bar



# Stratifié - HPL

## Original Collection

Plateau de table - *Tops*



Béton Concrete  
F 275



Marmara  
F 160 ST9



Minnesota Oak Greige  
H 160

cm	□			▭				○	
	60x60	70x70	80x80	60x70	110x70	120x70	120x80	Ø70	Ø120 *
24mm	6,8kg	8,1kg	10,9kg	7,5kg	12,9kg	14kg	16,2kg	6,4kg	21,3kg

\* 26 mm

 p297

Plateau stratifié - Chants en PVC - Disponible en épaisseur 24mm uniquement\*.  
HPL table top - PVC edges - Available only in thickness of 24mm\*.





# Stratifié-HPL

Original Collection

# Stratifié - HPL

## Chêne - Oak Halifax

Plateau de table - Tops



Chêne Halifax Naturel  
H 1180 ST37



Chêne Halifax Tabac  
H1181 ST37

cm	□			▭				○	
	60x60	70x70	80x80	60x70	110x70	120x70	120x80	Ø70	Ø120 *
24mm	5,9kg	8,3kg	10,4kg	7,2kg	12,7kg	13,7kg	16,1kg	6,5kg	19,7kg 26 mm
46mm	8,5kg	10,7kg	13,5kg	9,4kg	15,7kg	17,1kg	19,2kg	/	/

\* Uniquement: Naturel H 1180 ST37

\* Only: Naturel H 1180 ST37

 p297

Plateau stratifié aspect bois - Chants en PVC imitation « Bois de bout » - Touché « Feelwood » : suit les fibres du bois.

HPL table top with wood-like appearance - PVC edges - « Feelwood » touch : realistic look and feel of the wooden fibers..





# Stratifié-HPL

Chêne - Oak Halifax

# Méla miné

## Melamine



Plateau de table - Tops



Minnesota Oak Chocolat  
H441 Z5L



Chêne Halifax Naturel  
H 1180 ST37

		
cm	60x60	70x70
18mm	4,4kg	6,2kg

 p297

Plateau méla miné aspect bois - Chants en PVC imitation « Bois de bout »  
Touché « Feelwood » : suit les fibres du bois - Epaisseur 18mm.

*Melamine table top with wood-like appearance - PVC edges - « Feelwood »  
touch : realistic look and feel of the wooden fibers - Thickness 18mm.*





# Mélaminé

*Melamine*



# Odense

## Chêne-Oak

Plateau de table - *Tops*



Finition rustique naturelle brossée  
*Natural rustic brushed finish*

			
cm	60x60	70x70	120x70
30mm	8,4kg	11,1kg	19kg

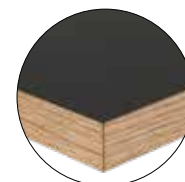

Plateau bois plaqué chêne - Finition rustique naturelle brossée - 4 couches de vernis polyuréthane satiné - Epaisseur 30mm.

*Wooden oak veneered top - Natural rustic brushed finish - 4 coats of polyurethane satin lacquer - Thickness 30mm.*

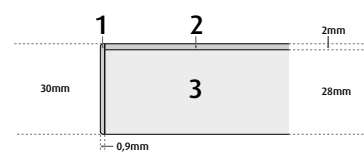

- 1. Chants plaqués
- 2. Plaquage Chêne
- 3. Aggloméré
- 1. Veneer edges
- 2. Oak veneer
- 3. Chipboard



# Odense

Chêne-Oak



# William

Buffet - Buffet



Wengé Louisiana  
Wenge Louisiana

Grey Bardolino Oak  
Grey Bardolino Oak



 p297

Structure en mélamine - Tablettes en stratifié - 4 roulettes dont 2 avec frein - Porte à droite - Meuble monté - Usage intérieur uniquement.  
Melamine structure - Laminated shelves - 4 casters, including 2 with brakes - Door on the right side - Assembled - Indoor use only.

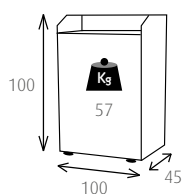



# William

# Jacky

Meuble poubelle - Waste bin



## OPTION

Poubelle PVC 80L  
PVC trash 80L

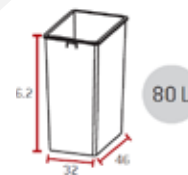

Wengé Louisiana  
Wenge Louisiana

Grey Bardolino Oak  
Grey Bardolino Oak

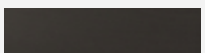

 p297

Structure en mélamine - Tablette en stratifié - Battant en inox lesté - 4 roulettes dont 2 avec frein - Fermeture à clé - Meuble monté  
Usage intérieur uniquement.

Melamine structure - Laminated shelf - Weighted stainless steel flap - 4 casters, including 2 with brakes - Key lock - Assembled  
Indoor use only.

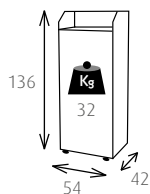



# Jacky





Extérieur - Outdoor

# Orléans

Chaise - Chair



Rôtin Noisette  
Nut Rattan

Structure en aluminium - Peinture époxy : Bamboo look caramel - Épaisseur tube 1,5mm - Diamètre tube 28mm - Tressage PE.  
Aluminum frame - Epoxy powder coating : Caramel Bamboo look - Tube thickness 1,5mm - Tube diameter 28mm - PE wicker.

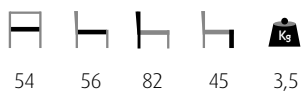

54 56 82 45 3,5



S4  
R16



# Orléans



# Rochelle

Fauteuil - *Armchair*



Rotin Noisette  
*Nut Rattan*

Structure en aluminium - Peinture époxy : Bamboo look caramel - Épaisseur tube 1,5mm - Diamètre tube 28mm - Tressage PE.  
*Aluminum frame - Epoxy powder coating : Caramel Bamboo look - Tube thickness 1,5mm - Tube diameter 28mm - PE wicker.*

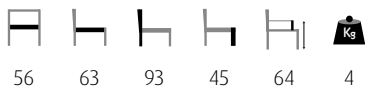

S4  
R16



# Rochelle

# Brest

Tabouret - Barstool



Rôtin Noisette  
Nut Rattan

Structure en aluminium - Peinture époxy : Bamboo look caramel - Épaisseur tube 1,5mm - Diamètre tube 28mm - Tressage PE.  
Aluminum frame - Epoxy powder coating : Caramel Bamboo look - Tube thickness 1,5mm - Tube diameter 28mm - PE wicker.



36 45 2



S4  
R16



# Brest

# Sorbonne

Chaise - Chair



Gris & Blanc  
Grey & White

Noir  
Black



Structure en aluminium - Peinture époxy : Bamboo look clair - Épaisseur tube 1,5mm - Diamètre tube 28mm - Tressage PE.  
Aluminum frame - Epoxy powder coating : Light Bamboo look - Tube thickness 1,5mm - Tube diameter 28mm - PE wicker.



S5  
R8,R9



# Sorbonne

# Madeleine

Fauteuil - Armchair



Gris & Blanc  
Grey & White

Noir  
Black



Structure en aluminium - Peinture époxy : Bamboo look clair - Épaisseur tube 1,5mm - Diamètre tube 28mm - Tressage PE.  
Aluminum frame - Epoxy powder coating : Light Bamboo look - Tube thickness 1,5mm - Tube diameter 28mm - PE wicker.

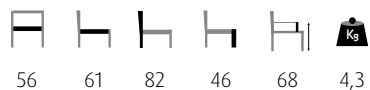

56 61 82 46 68 4,3



S5  
R8,R9



# Madeleine



# Passy

Tabouret - Barstool



Gris & Blanc  
Grey & White



Noir  
Black



Structure en aluminium - Peinture époxy : Bamboo look clair - Épaisseur tube 1,5mm - Diamètre tube 28mm - Tressage PE.  
Aluminum frame - Epoxy powder coating : Light Bamboo look - Tube thickness 1,5mm - Tube diameter 28mm - PE wicker.



39 76 2,5



S5  
R8,R9



# Passy

# Savana

Fauteuil - Armchair



Paille  
Straw

Olive  
Olive



Structure en acier - Peinture époxy : anthracite - Épaisseur tube 1mm - Diamètre tube 22mm - Tressage PE torsadé 5mm.  
Steel frame - Anthracite powder coating - Tube thickness 22x1mm - Tube diameter 22mm - Twisted PE rattan 5mm.

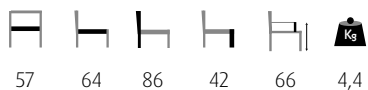

S1+R1  
S1+R2



# Savana

# Amsterdam

Fauteuil - *Armchair*



Paille  
Straw



Olive  
Olive



Anthracite  
Anthracite



Structure en aluminium - Peinture époxy : anthracite - Épaisseur tube 32x1,2mm à 19x2mm - Tressage PE torsadé 5mm.  
Aluminum frame - Anthracite powder coating - Tube thickness 32x1,2mm to 19x2mm - Twisted PE Rattan 5mm.



57 58 77 46 65 3,1



S1+R1  
S1+R2  
S1+R3



# Amsterdam

# Breda

Tabouret - Barstool



Paille  
Straw

Olive  
Olive

Anthracite  
Anthracite

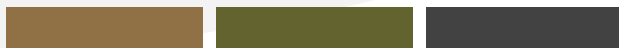

Structure en aluminium - Peinture époxy : anthracite - Épaisseur tube 32x1,2mm à 19x2mm - Tressage PE torsadé 5mm.  
Aluminum frame - Anthracite powder coating - Tube thickness 32x1,2mm to 19x2mm - Twisted PE Rattan 5mm.



S1+R1  
S1+R2  
S1+R3



# Breda



# Fiori

Stock  
Limité  
Limited  
Stock

Chaise - Chair



Paille  
Straw

Anthracite  
Anthracite



Structure en aluminium - Épaisseur tube 2,0mm - Diamètre tube 22mm - Peinture époxy : anthracite - Tressage PE torsadé 5mm  
Coussin polyester 3cm inclus.

Aluminum frame - Tube thickness 2,0mm - Tube diameter 22mm - Anthracite powder coating - Twisted PE rattan 5mm  
Polyester cushion 3cm included.

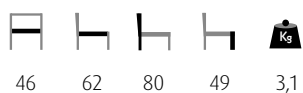

46 62 80 49 3,1



S1+R1  
S1+R3



# Fiori

# Fiori F

Stock  
Limité  
Limited  
Stock

Fauteuil - *Armchair*



Anthracite  
Anthracite

Structure en aluminium - Épaisseur tube 2,0mm - Diamètre tube 22mm - Peinture époxy : anthracite - Tressage PE torsadé 5mm  
Coussin polyester 3cm inclus.

Aluminum frame - Tube thickness 2,0mm - Tube diameter 22mm - Anthracite powder coating - Twisted PE rattan 5mm  
Polyester cushion 3cm included.

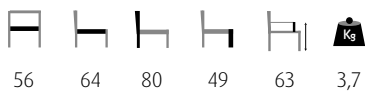

S1+R1  
S1+R3



# Fiori F

# Concorde

Fauteuil - *Armchair*



Anthracite  
Anthracite

Structure en aluminium - Peinture époxy : anthracite - Épaisseur tube 1,5mm - Diamètre tube 28mm - Corde textilène anthracite.  
Aluminum frame - Anthracite powder coating - Tube thickness 1,5mm - Tube diameter 28mm - Anthracite textilene ropes.

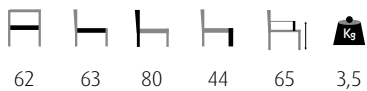



# Concorde

# Saint-Tropez

Fauteuil - *Armchair*



Noir  
Black



Gris Pierre  
Stone Grey



Structure en aluminium - Épaisseur tube 38x17x1,4mm et 25x2mm - Tressage PE rond 3,8mm avec fil d'acier.  
Aluminum frame - Tube thickness 38x17x1,4mm and 25x2mm - Round PE Rattan 3,8mm with metal wire.

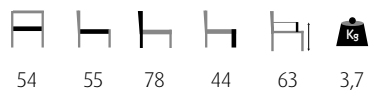

54 55 78 44 63 3,7





# Saint-Tropez



# Seine

Chaise - Chair



Camel & Blanc  
Camel & White



Structure en aluminium - Peinture époxy : Bamboo look naturel - Tube avant 28x1,5mm et tube arrière 24x1,5mm - Textilène 8x8.  
Aluminum frame - Epoxy powder coating : Natural bamboo look - Front tube 28x1,5mm & rear tube 24x1,5mm - 8X8 Textilene.

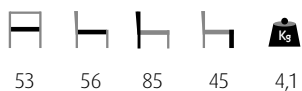

53 56 85 45 4,1



S16  
R10



# Seine

# Louvre

Chaise - Chair



Blanc & Bleu Océan  
White & Ocean Blue

Blanc & Pimento  
White & Pimento



Structure en aluminium - Peinture époxy : Bamboo look clair - Épaisseur tube 1,5mm - Diamètre tube 28mm - Textilène 8x8.  
Aluminum frame - Epoxy powder coating : Light Bamboo look - Tube thickness 1,5mm - Tube diameter 28mm - Textilene 8x8.



S5  
R5,R6



# Louvre

# Dauphine

Fauteuil - *Armchair*



Noir  
Black

Structure aluminium - Peinture époxy : noire - Tube avant 28x1,35mm et tube arrière 25x1,35mm - Textilène 2x2.  
Aluminum frame - Black powder coating - Front tube 28x1,35mm and rear tubes 25x1,35mm - 2X2 Textilene.

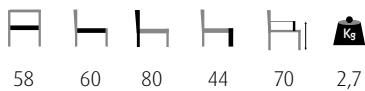

58 60 80 44 70 2,7



S2  
R4



# Dauphine

# Paris

Chaise - Chair



Noir  
Black

Bordeaux & Crème  
Bordeaux & Cream

Vert & Crème  
Green & Cream



Structure en aluminium - Peinture époxy : Bamboo look foncé - Épaisseur tube 1,5mm - Diamètre tube 28mm - Textilène 8x8.  
Aluminum frame - Epoxy powder coating : Dark Bamboo look - Tube thickness 1,5mm - Tube diameter 28mm - Textilene 8x8.

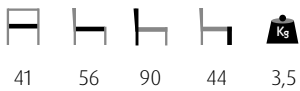

S6  
R13,R14,R15



# Paris



# Montmartre

Fauteuil - *Armchair*



Noir  
Black

Structure en aluminium - Peinture époxy : Bamboo look foncé - Épaisseur tube 1,5mm - Diamètre tube 28mm - Textilène 8x8.  
Aluminum frame - Epoxy powder coating : Dark Bamboo look - Tube thickness 1,5mm - Tube diameter 28mm - Textilene 8x8.

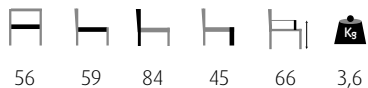

S6  
R13



# Montmartre

# Drouot



Chaise - Chair



Noir & Gris Clair  
Black & Light Grey



Structure aluminium - Peinture époxy : noire - Épaisseur tube 1,5mm - Diamètre tube 28mm - Textilène 8x8.  
Aluminum frame - Black powder coating - Tube thickness 1.5mm - Tube diameter 28mm - 8x8 Textilene.

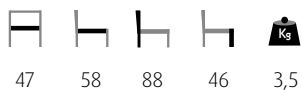

S2  
R11



# Drouot

# Trocadero

Fauteuil - *Armchair*



Noir & Gris Clair  
*Black & Light Grey*



Structure aluminium - Peinture époxy : noire - Épaisseur tube 1,5mm - Diamètre tube 28mm - Textilène 8x8.  
*Aluminum frame - Black powder coating - Tube thickness 1.5mm - Tube diameter 28mm - 8x8 Textilene.*

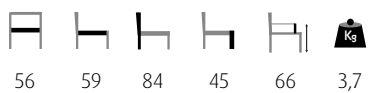

S2  
R11



# Trocadero

# Bastille

Chaise - Chair



Stock  
Limité  
Limited  
Stock



Anthracite  
Anthracite

Olive  
Olive

Pimento  
Pimento

Stock  
Limité  
Limited  
Stock



Structure en acier - Peinture époxy - Effet texturé - Épaisseur tube 1,5mm - Diamètre tube 22mm.  
Steel frame - Textured Epoxy powder coating - Tube thickness 1.5mm - Tube diameter 22mm.

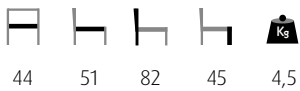

44 51 82 45 4,5



S7,S8,S9



# Bastille



# Bastille Bst

Tabouret - Barstool



Anthracite  
Anthracite

Olive  
Olive

Pimento  
Pimento

Stock  
Limité  
Limited  
Stock



Structure en acier - Peinture époxy - Effet texturé - Épaisseur tube 1,5mm - Diamètre tube 22mm.  
Steel frame - Textured Epoxy powder coating - Tube thickness 1.5mm - Tube diameter 22mm.

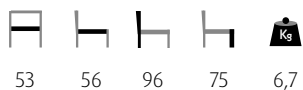

S7,S8,S9



# Bastille Bst

# Pigalle

Table - Table

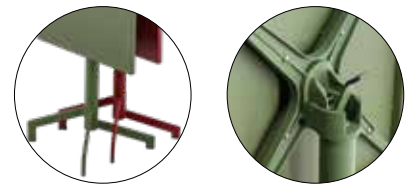





Anthracite  
Anthracite



Olive  
Olive



 2000 cycles

Pied de table en aluminium - Encastrable - Système basculant - Plateau en tôle d'acier - Peinture époxy - Effet texturé.  
Aluminum table base - Stackable - Fliptop mechanism - Steel sheet table top - Textured Epoxy powder coating.

      
60x60 42x42 75,5 41x103 8

     
S7,S9



# Pigalle

# Pack Bastille & Pigalle

Ensemble - Set



Anthracite  
Anthracite

 Pigalle: p204 / Bastille: p200

Ensemble composé de : **1** Table Pigalle - Anthracite + **4** Chaises Bastille - Anthracite.  
Set composed of : **1** Pigalle Table - Anthracite + **4** Bastille Chairs - Anthracite.



S7



# Pack Bastille & Pigalle

# Penelope

Chaise - Chair



Noir  
Black

Marsala  
Marsala



Monobloc polypropylène renforcé avec fibre de verre.  
*Polypropylene monobloc reinforced with glass fiber.*

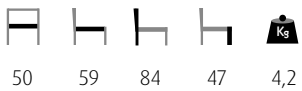

6max



CATAS

Test report  
343113



# Penelope



# Ulysse

Fauteuil - Armchair



Noir  
Black

Marsala  
Marsala



Monobloc polypropylène renforcé avec fibre de verre.  
*Polypropylene monobloc reinforced with glass fiber.*

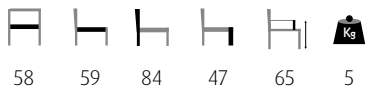

CATAS

Test report  
343116



# Ulysse

# Tom Bar 75

Tabouret - Barstool



Noir  
Black

Marsala  
Marsala

Olive  
Olive



Monobloc polypropylène renforcé avec fibre de verre.  
*Polypropylene monobloc reinforced with glass fiber.*



36 75 4



CATAS

Test report  
344047



# Tom Bar 75

# Monna

Chaise - Chair



Noir  
Black

Olive  
Olive

Octane  
Octane

Moutarde  
Mustard



Monobloc polypropylène renforcé avec fibre de verre.  
*Polypropylene monobloc reinforced with glass fiber.*

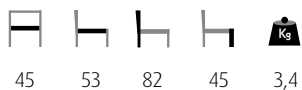

CATAS

Test report  
276554



# Monna

# Sky Pro

Fauteuil - Armchair



Noir  
Black

Olive  
Olive

Blanc  
White



Monobloc polypropylène renforcé avec fibre de verre.  
*Polypropylene monobloc reinforced with glass fiber.*

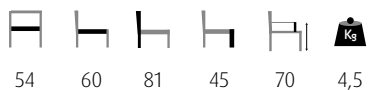

CATAS

Test report  
326232



# Sky Pro



# Maya

Chaise - Chair



Noir  
Black

Olive  
Olive

Gris Foncé  
Dark Grey

Blanc  
White



Monobloc polypropylène.  
*Polypropylene monobloc.*

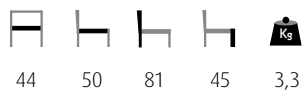

CATAS

Test report  
73610



# Maya

# Maya Bar 75

Tabouret - Barstool



Noir  
Black

Olive  
Olive

Gris Foncé  
Dark Grey

Blanc  
White



Monobloc polypropylène.  
*Polypropylene monobloc.*



CATAS

Test report  
236234



# Maya Bar 75

# Fado

Stock  
Limité  
Limited  
Stock

Fauteuil - *Armchair*



Anthracite  
*Anthracite*

Aquamarine  
*Aquamarine*

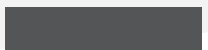

Monobloc polypropylène.  
*Polypropylene monobloc.*

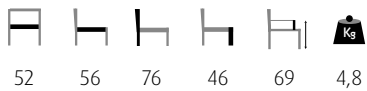



# Fado

# Atlantic

Fauteuil - *Armchair*



Noir  
Black

Serge Ferrari

Monobloc polypropylène renforcé avec fibre de verre - Textilène Serge Ferrari 2x2.  
*Polypropylene monobloc reinforced with glass fiber - 2x2 Textilene Serge Ferrari.*

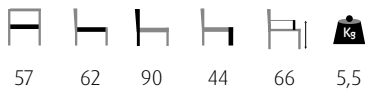

CATAS

Test report  
308018



# Atlantic



# Marcel

Chaise - Chair



Noir  
Black

Monobloc polypropylène renforcé avec fibre de verre.  
*Polypropylene monobloc reinforced with glass fiber.*

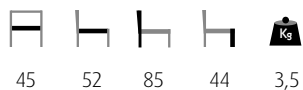

CATAS

Test report  
294903



# Marcel

# Marcel XL

Fauteuil - Armchair



Noir  
Black

Monobloc polypropylène renforcé avec fibre de verre.  
*Polypropylene monobloc reinforced with glass fiber.*



57 52 85 44 68 3,9



CATAS

Test report  
294887



# Marcel XL

# Marcel Bar 75

Tabouret - Barstool



Noir  
Black

Monobloc polypropylène renforcé avec fibre de verre.  
*Polypropylene monobloc reinforced with glass fiber.*



CATAS

Test report  
294883



# Marcel Bar 75

# Daytona

Chaise - Chair



Gris Foncé  
Dark Grey

Monobloc polypropylène renforcé avec fibre de verre - Imitation rotin.  
*Polypropylene monobloc reinforced with glass fiber - Rattan look.*

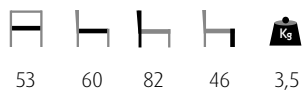

CATAS

Test report  
201747



# Daytona



# Panama

Fauteuil - *Armchair*



Gris Foncé  
*Dark Grey*

Monobloc polypropylène renforcé avec fibre de verre - Imitation rotin.  
*Polypropylene monobloc reinforced with glass fiber - Rattan look.*

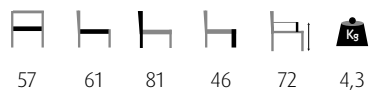

CATAS

Test report  
201753



# Panama

# Jamaica

Chaise - Chair



Gris Foncé  
Dark Grey

Monobloc polypropylène renforcé avec fibre de verre - Imitation rotin.  
*Polypropylene monobloc reinforced with glass fiber - Rattan look.*

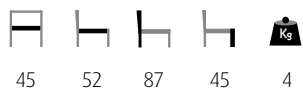

CATAS

Test report  
144188



# Jamaica

# Jamaica F

Fauteuil - *Armchair*



Gris Foncé  
*Dark Grey*

Monobloc polypropylène renforcé avec fibre de verre - Imitation rotin.  
*Polypropylene monobloc reinforced with glass fiber - Rattan look.*

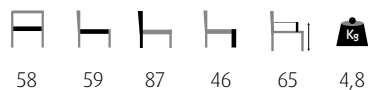

CATAS

Test report  
127165



# Jamaica F

# Jamaica Bst

Tabouret - Barstool



Gris Foncé  
Dark Grey

Monobloc polypropylène renforcé avec fibre de verre - Imitation rotin.  
*Polypropylene monobloc reinforced with glass fiber - Rattan look.*

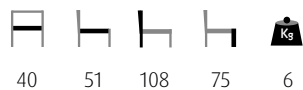

40 51 108 75 6



CATAS

Test report  
157230



# Jamaica Bst







# Kys

Table - Table



Noir  
Black

Résine renforcée par une structure métallique - Encastrable - Système basculant - Vérins de réglage.  
Resin reinforced by a metallic frame - Stackable - Fliptop mechanism - Adjustable foot plugs.

     
60x60 74 47x100 7,3





# Kys





# Kys Bar

Table - Table



Noir  
Black

Résine renforcée par une structure métallique - Encastrable - Système basculant - Vérins de réglage.  
Resin reinforced by a metallic frame - Stackable - Fliptop mechanism - Adjustable foot plugs.

     
60x60 108 47x134 7,5





# Kys Bar

# Pack Sky Pro & Kys

Ensemble - Set



Noir  
Black

 Kys: p242 / Sky Pro: p216

Ensemble composé de : **2** tables Kys - Noir + **4** fauteuils Sky Pro - Noir.  
Set composed of : **2** Kys tables - Black + **4** Sky Pro armchairs - Black.



# Pack Tom Bar 75 & Kys Bar

Ensemble - Set



Noir  
Black

 Kys Bar: p244 / Tom Bar: p212

Ensemble composé de : **2** tables Kys Bar - Noir + **4** tabourets Tom Bar 75 - Noir.  
Set composed of : **2** Kys Bar tables - Black + **4** Tom Bar 75 barstools - Black.



# Pack Maya & Kys

Ensemble - Set



Noir  
Black

 Kys: p250 / Maya: pxxx

Ensemble composé de : **2** tables Kys - Noir + **4** chaises Maya - Noir.  
Set composed of : **2** Kys tables - Black + **4** Maya chairs - Black.



# Pack Maya Bar 75 & Kys Bar

Ensemble - Set



Noir  
Black

 Kys Bar: p251 / Maya Bar: pxxx

Ensemble composé de : **2** tables Kys Bar - Noir + **4** tabourets Maya Bar 75 - Noir.  
Set composed of : **2** Kys Bar tables - Black + **4** Maya Bar 75 barstools - Black.





# Eolo Pureti 250x250cm

Stock  
Limité  
Limited  
Stock

Parasol - Parasol



Anthracite  
Anthracite



Parasol aluminium laqué avec 4 baleines en aluminium (20x14mm) - Ouverture push-up avec système d'ouverture/fermeture et verrouillage - Tissu Olefin (190gr) qui neutralise par photocatalyse les gaz et substances nocives - **Vendu sans le pied de parasol.**  
*Lacquered aluminum parasol with 4 aluminum ribs (20x14mm) - Push-up opening with open/close/lock system - Olefin fabric (190gr) neutralizes gases and harmful substances by photocatalysis - Sold without the parasol base.*

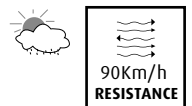
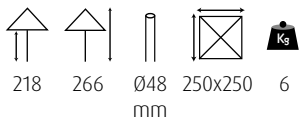



# Eolo Pureti

# Canto

Stock  
Limité  
Limited  
Stock

Pied de parasol - *Parasol base*



Anthracite  
*Anthracite*

Base carrée en acier, laquée avec peinture en poudre de polyester polymérisée au four - Protections d'angle en acier INOX - Tige filetée au mât du parasol avec languette-frein intérieur pour éviter tout contact direct de la vis avec le mât du parasol - Convient pour le parasol Eolo Pureti 250x250cm.

*Square steel base, lacquered with oven-cured polyester powder paint - Stainless steel corner protectors - Threaded rod on the parasol pole with inner locking tabs to prevent direct contact of the screws with the parasol pole - Suitable for the parasol Eolo Pureti 250x250cm.*

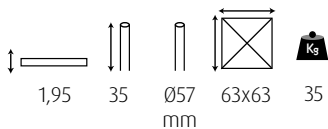



# Canto

# Verona

Pied de table - *Table base*

Système basculant - *Fliptop mechanism*



Poignée: Facile à porter.  
*Handle: Easy to carry.*



2 crochets pour suspendre les sacs.  
*2 hooks for hanging bags.*



Encastrable: Facile à ranger.  
*Stackable: Easy to store.*



Verona 3 \*



Verona Double

Noir  
*Black*

Base et tube en aluminium - Peinture époxy - Système basculant en polyamide - Vérins de réglage.

*Aluminium base and tube - Epoxy powder coating - Fliptop mechanism - Adjustable feet.*



S13

Verona 3 \*

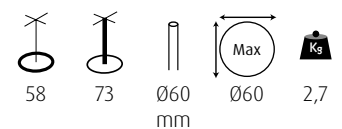

Verona Double

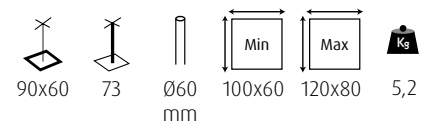

\* Modèle déposé  
\* *Registered design*

# Verona

Pied de table - *Table base*



Verona 4

Verona 4 Bar

Epoxy Argent\*  
Silver Epoxy\*

Anthracite  
Anthracite

Noir  
Black

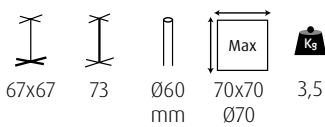

Verona 4

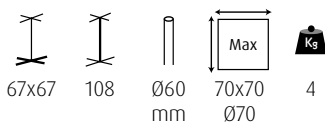

Verona 4 Bar

Base et tube en aluminium - Peinture époxy - Système basculant en polyamide - Vérins de réglage.

*Aluminium base and tube - Epoxy powder coating - Flip-top mechanism - Adjustable feet.*

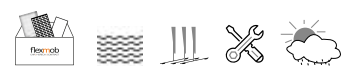

S10,S11,S13

\* Uniquement pour Verona 4.  
\* Only for Verona 4.

# Monza

Pied de table - *Table base*



Monza



Monza Bar

Anthracite  
Anthracite

Base et tube en aluminium - Peinture époxy - Vérins de réglage.

*Aluminium base and tube - Epoxy powder coating - Adjustable feet.*

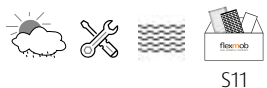

S11

Monza



63x63



73

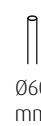

Ø60  
mm



Max  
70x70  
Ø70



4

Contrepoids  
Extraveight  
Kg

1,5

Monza Bar



63x63



108

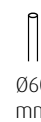

Ø60  
mm

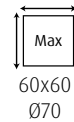

Max  
60x60  
Ø70



5,8

Contrepoids  
Extraveight  
Kg

3



# Monza



# Berlin

Pied de table - *Table base*



Berlin 2



Berlin 4

Noir  
*Black*

Base et tube en aluminium - Peinture époxy - Vérins de réglage.  
*Aluminium base and tube - Epoxy powder coating - Adjustable feet.*

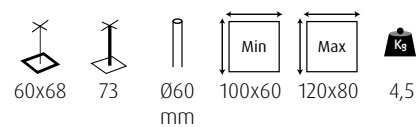

Berlin 2

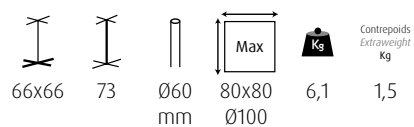

Berlin 4

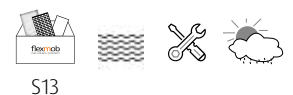

S13

# Berlin

Pied de table - *Table base*



Berlin 4 Bar

Noir  
Black



Base et tube en aluminium - Peinture époxy - Vérins de réglage.  
*Aluminium base and tube - Epoxy powder coating - Adjustable feet.*



S13

66x66	108	Ø60 mm	Max 70x70 Ø70	6,6	3

Berlin 4 Bar

# Empire

Pied de table - Table base



Empire 3



Empire 4



Empire 4 Bar

Noir  
Black



Aluminium forgé noir - Vérins de réglage.  
Cast aluminum - Powder coated in black - Adjustable feet.



S12

Empire 3				
Empire 4				
Empire 4 Bar				

# Empire

Pied de table - *Table base*



Empire 2



Empire Grande

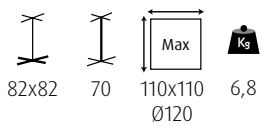

Empire 2

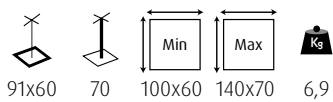

Empire Grande

Noir  
Black



Aluminium forgé noir - Vêrins de réglage.  
Cast aluminum - Powder coated in black - Adjustable feet.



S12

# Bistrot

Pied de table - *Table base*



Bistrot 3 H43



Bistrot 3

Noir  
Black

Fonte d'acier - Epoxy noir - Vérins de réglage. \*  
Cast iron - Powder coated in black - Adjustable feet. \*



S 15

⚠ \*Ces articles peuvent rouiller en utilisation extérieure.  
\*This item may rust when used outdoor.

Bistrot 3 H43

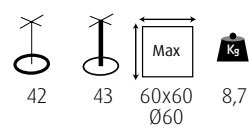

Bistrot 3

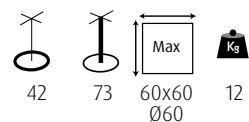

# Bistrot

Pied de table - Table base



Bistrot 4



Bistrot 3 Bar

Noir  
Black

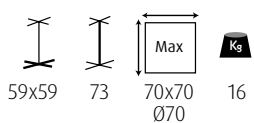

Bistrot 4

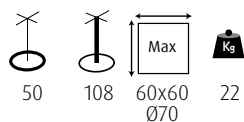

Bistrot 3 Bar

Fonte d'acier - Epoxy noir - Vérins de réglage.\*  
Cast iron - Powder coated in black - Adjustable feet.\*



S 15

\*Ces articles peuvent rouiller en utilisation extérieure. ⚠️  
\*This item may rust when used outdoor.

# Compact Easy

Plateau de table - *Table top*



Cosmos  
685



California Oak  
679



Dark Marble  
1541

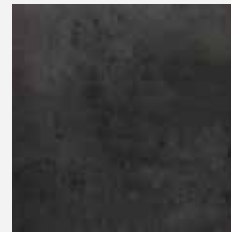

Dark Metal  
919



Jungle Wood  
580



Stone Grey  
637



White Marble  
653

	
cm	65x65
12 mm	3,2kg

Plateau 12mm - Chants droits - Système de fixation universel (visserie fournie) - Protection UV.

*12mm top - Straight edges - Universal fixing system (screws included) - UV resistant.*



Compact  
Easy

 Risque de décoloration des couleurs foncées au soleil.  
*Risk of dark colors fading if sun exposure.*

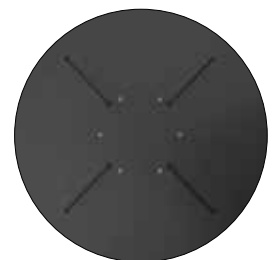

Inserts pour Verona + rails pour autre système de fixation en croix.

*Inserts for Verona + grooves for other cross fixing systems.*



# Compact Easy



# Topalit Classic

Plateau de table - *Table top*

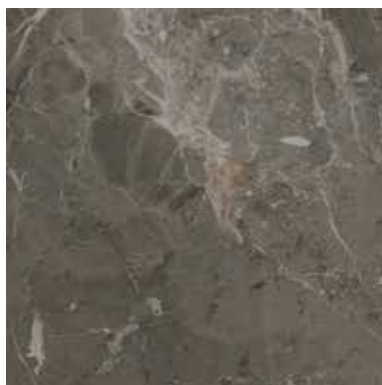

Veneto  
0249



Atacama Cherry  
0222



	□	
cm	60x60	70x70
34 mm	5,9kg	8kg

Plateau stratifié moulé - Chant 34mm.

*Molded laminated top - 34mm edges.*



**topalit**  
ALUMI



⚠ Risque de décoloration des couleurs foncées au soleil.  
*Risk of dark colors fading if sun exposure.*



# Topalit Classic

# Werzalit Classic

Plateau de table - *Table top*



Indian Shesham  
4525



Iceland Oak II  
4622



Grey Marble  
5666



Metallo  
5672

	□		○
cm	60x60	70x70	Ø60
34 mm	5,9kg	8kg	5,3kg

Plateau stratifié moulé - Chant 32mm.

*Molded laminated top - 32mm edges.*



⚠ Risque de décoloration des couleurs foncées au soleil.  
*Risk of dark colors fading if sun exposure.*

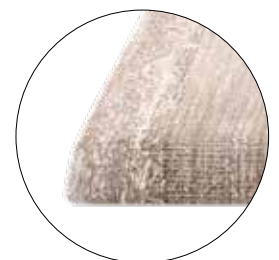



# Werzalit Classic

# Werzalit Cerclés

Plateau de table - *Table top*



Marrakesh  
5717



Mermer  
5410

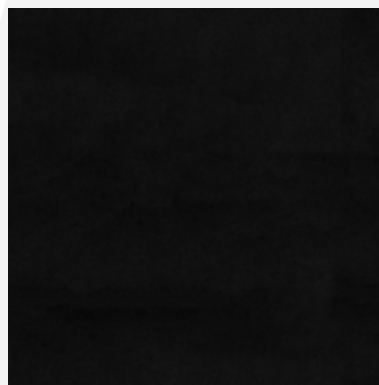

Black Siyah  
3190



Laiton  
Brass

	○
cm	Ø60
30 mm	4,9kg

Plateau stratifié moulé - Cerclage métallique finition laiton - Chant 30mm.

*Rimmed table top - Brass finish - 30mm edges.*



⚠ Risque de décoloration des couleurs foncées au soleil.  
*Risk of dark colors fading if sun exposure.*





# Werzalit Cerclés





Réception - Catering



# Daisy

Stock  
Limité  
Limited  
Stock

Chaise - *Chair*



Argent & Noir  
*Silver & Black*

Structure en acier 20x20x1mm - Assise en mousse moulée - Assise et dos garnis de similicuir.  
*Steel frame 20x20x1mm - Molded foam seat - Seat and back upholstered with faux-leather.*





# Daisy

# Tiffany

Stock  
Limité  
Limited  
Stock

Chaise - Chair



Noir  
Black

Monobloc polypropylène.  
*Polypropylene monobloc.*

41 43 92 47 4,3





# Tiffany

# Napoléon

Stock  
Limité  
Limited  
Stock

Chaise - Chair

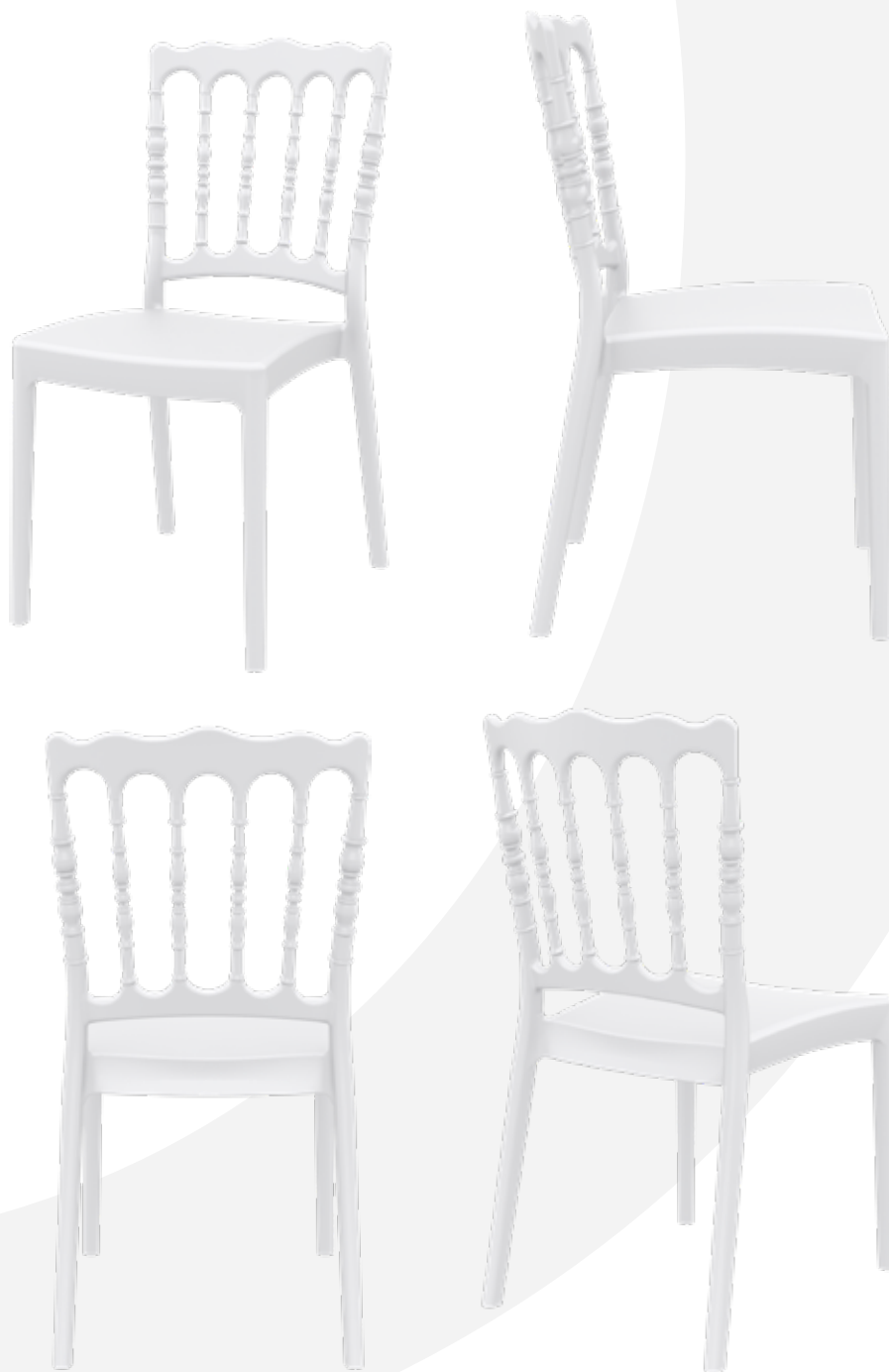

Blanc  
White



Monobloc polypropylène.  
*Polypropylene monobloc.*





# Napoléon

# XL 180

Table - Table

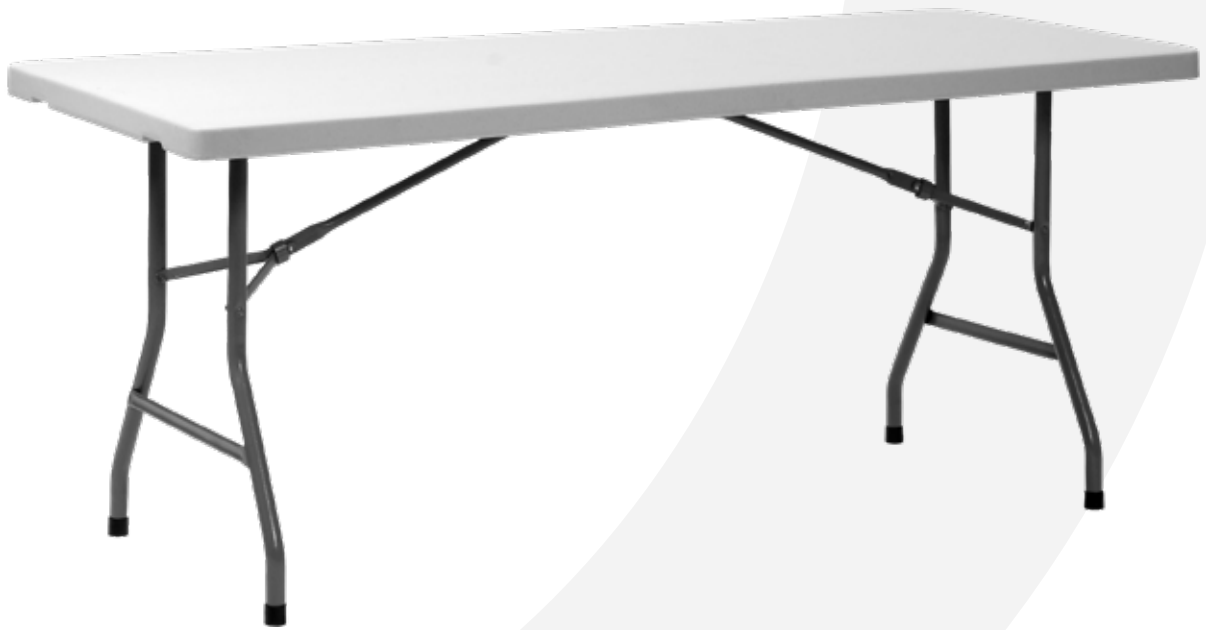

Blanc  
White



Piètement métallique pliant - Diamètre tube 28mm - Plateau polyéthylène épaisseur 45mm.  
Folding metal table base - Tube diameter 28mm - Polyethylene table top thickness 45mm.



182x75 74 14



# Cocktail 80

Table - Table

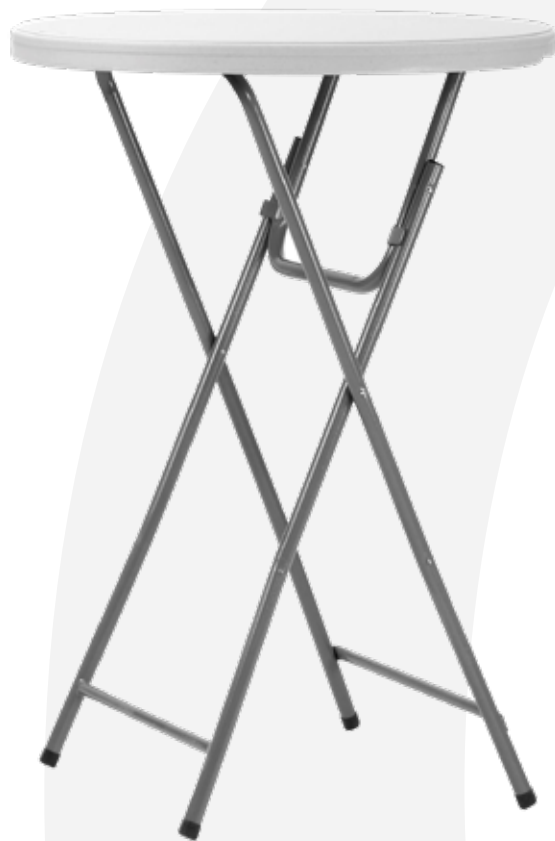

Blanc  
White



Piètement métallique pliant - Diamètre tube 22mm - Plateau polyéthylène épaisseur 45mm.  
*Folding metal table base - Tube diameter 22mm - Polyethylene table top thickness 45mm.*



81 110 8



# Osaka

Nappe - Cover



Noir  
Black



---

Comprend : 1 nappe + 1 cover top - Finition stretch 100% polyester - Renforts sur les pieds.  
*Consists of 1 table cover + 1 topper - 100% stretch polyester - Foot reinforcements.*

---

# Pack Cocktail 80 & Osaka

Ensemble - Set



Noir  
Black

Ensemble composé de : **1** table Cocktail 80 + **1** nappe Osaka - Noir avec le cover top.  
Set composed of : **1** Cocktail 80 table + **1** Osaka cover - Black with a cover top.





# Divers - Miscellaneous Infos

# Informations techniques

## Technical information

### Textilène - *Textilene*

Tissu en fil de polyester revêtu de PVC.  
*Polyester yarn fabric coated with PVC.*

p86-198 →  Boîte échantillons disponible  
*Samples box available*

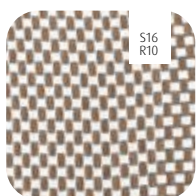

Seine  
 Camel & Blanc  
*Camel & White* 8x8

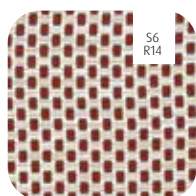

Paris  
 Bordeaux & Crème  
*Bordeaux & Cream* 8x8

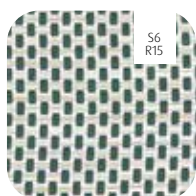

Paris  
 Vert & Crème  
*Green & Cream* 8x8

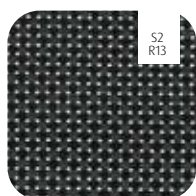

Paris/Montmartre  
 Noir  
*Black* 8x8



Dauphine  
 Noir  
*Black* 2x2



Drouot/Trocadero  
 Noir & Gris Clair  
*Black & Light Grey* 8x8



Louvre  
 Blanc & Bleu Océan  
*White & Ocean Blue* 8x8

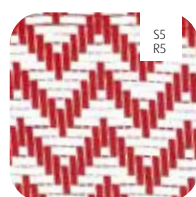

Louvre  
 Blanc & Pimento  
*White & Pimento* 8x8

### Rotin Tressé - *Weaved*

p160-184 →  Boîte échantillons disponible  
*Samples box available*



Amsterdam/Breda  
 Olive  
*Olive* 5mm



Amsterdam/Breda  
 Paille  
*Straw* 5mm



Amsterdam/Breda  
 Anthracite  
*Anthracite* 5mm

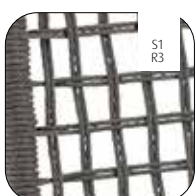

Fiori/Fiori F  
 Anthracite  
*Anthracite* 5mm



Fiori/Fiori F  
 Paille  
*Straw* 5mm

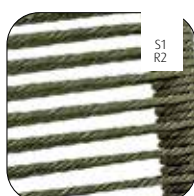

Savana  
 Olive  
*Olive* 5mm



Savana  
 Paille  
*Straw* 5mm



Concorde  
 Anthracite  
*Anthracite*



Saint-Tropez  
 Noir  
*Black* 3,8mm

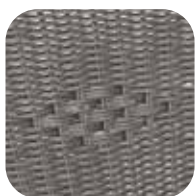

Saint-Tropez  
 Gris Pierre  
*Stoney Grey* 3,8mm

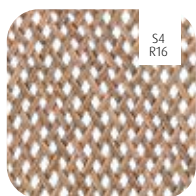

Rochelle  
 Paille  
*Straw*

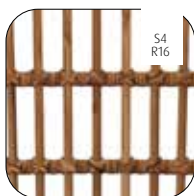

Orléans  
 Paille  
*Straw*



Brest  
 Paille  
*Straw*



Sorbonne/Passy  
 Madeleine  
 Gris & Blanc  
*Grey & White*



Sorbonne/Passy  
 Madeleine  
 Noir  
*Black*

# Informations techniques

## Technical information

### Polypropylène - Polypropylene

p208-249 →  Boîte échantillons disponible  
Samples box available



Monna/Maya/Ulysse/Atlantic/  
Penelope/Tom Bar/Sky Pro/  
Marcel/Marcel XL/Marcel Bst  
Noir Matte  
Black Matte



Monna  
Moutarde  
Moutarde



Monna/Maya/Tom Bar/Sky Pro  
Olive  
Olive



Monna  
Octane  
Octane



Ulysse/Penelope/  
Tom Bar  
Marsala  
Marsala



Maya/Sky  
Blanc  
White



Maya  
Anthracite  
Anthracite



Fado  
Aquamarine  
Aquamarine



Fado  
Anthracite  
Anthracite



Daytona/Panama/Jamaica  
Jamaica F/Jamaica Bst  
Gris Foncé  
Dark Grey

### Métal - Metal

p200-204 →  Boîte échantillons disponible  
Samples box available



Pigalle/Bastille/Bastille F/  
Bastille Bst  
Olive  
Olive

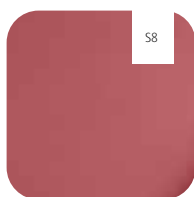

Bastille/Bastille F/  
Bastille Bst  
Pimento  
Pimento



Pigalle/Bastille/Bastille F/  
Bastille Bst  
Anthracite  
Anthracite

# Informations techniques

## Technical information

### Compact Easy - *Compact Easy*

Chants droits - Système de fixation universel.  
*Straight edges - Universal fixing system.*

p264

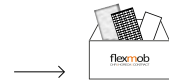

Boîte échantillons disponible  
*Samples box available*



Cosmos  
685



California Oak  
679



Black Marble  
1541



Dark Metal  
919



Jungle Wood  
580



Stone Grey  
637



White Marble  
653

### Topalit - *Topalit*

Plateau stratifié moulé.  
*Rimmed table top.*

p266



Atacama Cherry  
0222



Veneto  
0249

### Werzalit Cerclés - *Werzalit Rimmed*

Plateau stratifié moulé  
Cerclage métallique finition laiton.  
*Rimmed table top - Brass finish.*

p270

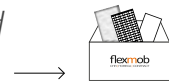

Boîte échantillons disponible  
*Samples box available*



Marrakesh  
5717



Mermer  
5410



Black Siyah  
3190

### Werzalit Classique - *Werzalit Classic*

Plateau stratifié moulé.  
*Molded laminated top.*

p268

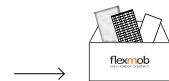

Boîte échantillons disponible  
*Samples box available*



Indian Shesham  
4525

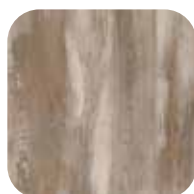

Iceland Oak II  
4622



Grey Marble  
5666



Metallo  
5672

# Informations techniques

## Technical information

### Tables Basses - Low Tables



Maryne  
Marbre noir  
Black marble

p128



Jolyne  
Mango  
Mango

p130



Jolyne  
Noir  
Black

p130



Ellen  
Naturel  
Natural

p132

### Stratifié Original Collection - HPL Original collection

Plateau stratifié.  
Molded laminated top.

p146



Béton Concrete  
F275



Marmara  
F 160 ST9



Minnesota Oak Greige  
H 160

### Stratifié Chêne - HPL Oak Halifax

p148

Plateau stratifié aspect bois touché «feelwood».  
«Feelwood» wood-look laminate top.



Chêne Halifax  
Naturel H1180 ST37

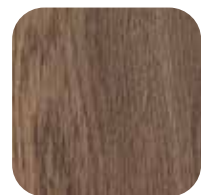

Chêne Halifax  
Tabac H1181 ST37

### Mélaminé - Melamine

p150

Plateau mélaminé aspect bois touché «feelwood».  
«Feelwood» wood-look melamine top.



Chêne Halifax  
Naturel H1180 ST37



Minnesota Oak  
Chocolat H441 Z5L

### Odense

p152

Bois plaqué chêne finition rustique naturelle brossée.  
Oak veneer with natural rustic brushed finish.



Chêne  
Oak

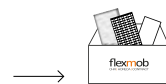

Boîte échantillons disponible  
Samples box available



# Informations techniques

## Technical information

Revêtements - Upholstery

### Entretien Maintenance

Le nettoyage et l'entretien réguliers des tissus d'ameublement prolongent leur durée de vie et empêchent la formation de salissures permanentes. Une solution d'eau et de savon doux peut être utilisée pour nettoyer le tissu.

### Conservation

Le boulochage des tissus est un processus naturel et peut ne pas être complètement éliminé. L'exposition à la lumière UV et aux sources de chaleur peut provoquer une décoloration du tissu (ceci concerne principalement les couleurs intensives). Pour des raisons technologiques, la teinte d'un tissu peut différer d'un ton par rapport à l'échantillon présenté dans le catalogue. Les photos sont non contractuelles. Les tissus sont conformes aux exigences du règlement européen sur les produits chimiques dangereux (REACH) n° 1907/2006, annexe XVII.

### Nettoyage

Étape 1: Enlevez soigneusement l'excès de saleté.  
Étape 2: Trempez la tache dans de l'eau froide et épongez-la avec une serviette en papier.  
Étape 3: Laissez sécher.

### Maintenance

Regular cleaning and maintenance of upholstery fabrics prolongs their life and prevents the formation of permanent soiling. A mild soap and water solution can be used to clean the fabric.

### Preservation

Pilling of fabrics is a natural process and may not be completely eliminated. Exposure to UV light and heat sources can cause discoloration of the fabric (this applies mainly to dark colours). For technological reasons, the shade of a fabric may differ by one shade from the sample shown in the catalog. Photos are non-contractual. Fabrics comply with the requirements of the European regulation on hazardous chemicals (REACH) n° 1907/2006, annex XVII.

### Cleaning

Step 1: Carefully remove excess dirt.  
Step 2: Soak the stain in cold water and blot with a paper towel.  
Step 3: Allow to dry.

## Aragon • Simone, Auguste, René



Vert 39  
Green 39



Terra 59  
Terra 59

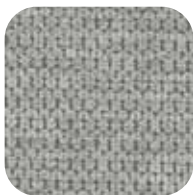

Gris Clair 83  
Light Grey 83

### Composition

5% NY  
95% PES

Poids - Weight  
340 g/m<sup>2</sup> (+/-5%)

Test Martindale  
45.000-60.000 tours min.

Largeur rouleau  
Usable width of roll  
140 cm.

[www.davis.pl/kolekcja/aragon](http://www.davis.pl/kolekcja/aragon)



BS 5852  
part 1  
EN 1021-1



WATER  
REPELLENT



DAVIS  
FABRICS

## Gava • Mélina, Sandra



Gris 18  
Grey 18

### Composition

100% PES

Poids - Weight  
450 g/m<sup>2</sup>

Test Martindale  
90.000/100.000 tours min

Largeur rouleau  
Usable width of roll  
140 cm.

[www.davis.pl/kolekcja/gava](http://www.davis.pl/kolekcja/gava)



BS 5852  
part 1  
EN 1021-1



WATER  
REPELLENT



RECYCLED  
POLYESTER



OEKO-TEX®  
STANDARD 100  
SWISS TESTER



Global Recycled  
Standard

DAVIS  
FABRICS

# Informations techniques

## Technical information

Revêtements - Upholstery

### Luis • Ralph, Zoé



Vert 34  
Green 34



Bleu 75  
Blue 75



Gris 90  
Grey 90



Rouille 52  
Rusty 52

#### Composition

100% PES

#### Poids - Weight

350 g/m<sup>2</sup>

#### Test Martindale

20.000-30.000 tours min.

Largeur rouleau - Usable width  
of roll

140 cm.



EN 1021-1  
BS 5852  
part 1



WATER  
REPELLENT



REACH  
COMPLIANCE

DAVIS  
FABRICS

[www.davis.pl/kolekcja/luis](http://www.davis.pl/kolekcja/luis)

### Monolith • Alfonso, Emile, Arnold, Willy, Lautrec S, Maurice, Maurice Bst, Oscar Bst



Anthracite 92



Burgundy 69



Gold 48



Petrol 76



Olive 38

#### Composition

100% PES

#### Poids - Weight

330g/m<sup>2</sup> (+/-5%)

#### Test Martindale

90.000/100.000 tours min.

#### Largeur rouleau

Usable width of roll

140 cm.



EN 1021-1  
BS 5852  
part 1



WATER  
REPELLENT



REACH  
COMPLIANCE

DAVIS  
FABRICS

[www.davis.pl/kolekcja/monolith](http://www.davis.pl/kolekcja/monolith)

### Grace • Paulette, Adèle, Colette, Victoire Bst



Corde 16  
Straw 16

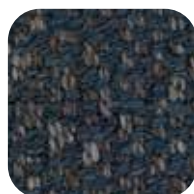

Tempête 77  
Storm 77

#### Composition

70% rPES

30% PES

#### Poids - Weight

600g/m<sup>2</sup> (+/-5%)

#### Test Martindale

60.000/70.000 tours min.

#### Largeur rouleau

Usable width of roll

140 cm.



BS 5852  
part 1  
EN 1021-1



EASY  
CLEAN



RECYCLED  
POLYESTER



REACH  
COMPLIANCE



DAVIS  
FABRICS

[www.davis.pl/kolekcja/grace](http://www.davis.pl/kolekcja/grace)

### Cloud • Paulette, Adèle, Colette, Victoire Bst



Pierre 87  
Stone 87



Tempête 97  
Storm 97

#### Composition

100% PES

#### Poids - Weight

390 g/m<sup>2</sup> (+/-10%)

#### Test Martindale

90.000/100.000 tours min.

#### Largeur rouleau

Usable width of roll

140 cm.



EN 1021-1  
BS 5852  
part 1



EASY  
CLEAN



RECYCLED  
POLYESTER



REACH  
COMPLIANCE



DAVIS  
FABRICS

[www.davis.pl/kolekcja/cloud](http://www.davis.pl/kolekcja/cloud)

# Informations techniques

## Technical information

Revêtements - Upholstery

### Miss • Ralph, Zoé



Beige 032  
Beige 032



Gris/Brun 056  
Brown/Grey 056



Olive 144  
Olive 144



Orange 106  
Orange 106

Composition  
96% PES 4%NY

Poids - Weight  
410g/m<sup>2</sup>

Test Martindale  
40.000 tours min.

Largeur rouleau  
Usable width of rol  
142 cm.

ote

### Colorado • Mikka, Olaf, Kyle, Jacob, Wendy



Cuoi



Anthracite

Composition  
100% PU  
81% PES + 15% Cotton  
+ 4% Viscose

Poids - Weight  
630g/m<sup>2</sup> (+/-5%)

Test Martindale  
>100.000 tours min.

Largeur rouleau  
Usable width of rol  
140 cm.



BS 5852  
EN 1021-1  
part 1



REACH  
COMPLIANCE



elastron

[www.elastrongroup.com/en/upholstery/fabrics/colorado](http://www.elastrongroup.com/en/upholstery/fabrics/colorado)

### Brego • Noélia



Gris 10  
Grey 10

Composition  
100% PES

Poids - Weight  
380g/m<sup>2</sup>

Test Martindale  
30.000 tours min

Largeur rouleau  
Usable width of rol  
140 cm.

[www.fabb.pl/brego-collection](http://www.fabb.pl/brego-collection)

fabb

### Ezra • Madison, Lena



Anthracite 7006  
Anthracite 7006



Rouille 9244  
Rusty 9244



Gris Clair 9502  
Light Grey 9502



Brun Clair 9811  
Light Brown 9811

Composition  
100% PES

Poids - Weight  
349g/m<sup>2</sup> (+/-5%)

Test Martindale  
>100.000 tours min.

Largeur rouleau  
Usable width of rol  
145 cm.



TEXTUM

[www.textum-stoffe.com/products-detail.html?fabric\\_name=Ezra](http://www.textum-stoffe.com/products-detail.html?fabric_name=Ezra)

### Lotos • Budapest, Budapest Bst, Brooklyn, Brooklyn Bst, Pub, Pub Bst



Olive 9430



Terra 9244



Noir 7006  
Black 7006



Éléphant 5272  
Elephant 5272



Cappuccino 5582



Bordeaux 5269

Composition  
100% PU  
Poids - Weight  
392g/m<sup>2</sup> (+/-5%)  
Test Martindale  
>100.000 tours min.  
Largeur rouleau  
Usable width of rol  
140 cm.



[www.textum-stoffe.com/products-detail.html?fabric\\_name=Lotos](http://www.textum-stoffe.com/products-detail.html?fabric_name=Lotos)

### PU • Floriane II, Floriane Bst II



Chocolat 928  
Chocolate 928



Noir 9100  
Black 9100



Taupe 926  
Taupe 926

Composition  
66% PU  
30% PES  
1,3% CV  
2,7% COT  
Poids - Weight  
340g/m<sup>2</sup> (+/-5%)  
Test Martindale  
100.000 tours min.  
Largeur rouleau  
Usable width of rol  
144 cm.

### Victory • Barossa



Cognac

Composition  
100% PU  
Poids - Weight  
440g/m<sup>2</sup>  
Test Martindale  
50.000 tours min

### Cortes • Cuba, Cuba double



Brun Clair 41  
Light Brown 41

Composition  
100% PES  
Poids - Weight  
330g/m<sup>2</sup>  
Test Martindale  
35.000 tours min.

[www.fabb.pl/cortes-collection](http://www.fabb.pl/cortes-collection)

**fabb**

### LUXOR • Pickup, Splash



Anthracite

Cognac

Composition  
100% PES  
Poids - Weight  
310g/m<sup>2</sup>  
Test Martindale  
25.000 tours min.

### Softyl • Peak, Condor, Alicia, Capri Bst



Anthracite



Cognac

Composition  
100% PES  
Poids - Weight  
360g/m<sup>2</sup>  
Test Martindale  
45.000 tours min.

## Proclean

Une incroyable facilité de nettoyage.  
*Incredible ease of cleaning.*



1. Apparition de la tache.  
*1. Appearance of the stain.*



2. Une goutte d'eau suffit pour éliminer cette tache tenace (Patientez 10 secondes).  
*2. A drop of water will be sufficient to remove this stubborn stain. (Wait 10 seconds).*



3. Frottez légèrement en effectuant des mouvements circulaires et votre tache disparaît.  
*3. Lightly rub in a circular motion and poof your stain is gone!*

### Procédure de nettoyage:

Son matériel remanié donnera à votre mobilier un look scintillant. Le produit a été testé sur des taches suivantes dans un laboratoire CTL® indépendant conformément à la norme DIN EN 12720:

- |                 |                 |                  |
|-----------------|-----------------|------------------|
| • Stylo à bille | • Huile d'olive | • Rouge à lèvres |
| • Moutarde      | • Café          | • Beurre         |
| • Confiture     | • Thé           | • Cirage         |
| • Ketchup       | • Jus de fruit  | • Chocolat       |

### Un confort et une douceur inégalés:

Nos matériaux Proclean se lavent très facilement et permettent d'éliminer pratiquement toutes les taches sans affecter les couleurs et la qualité des matériaux. Ce matériel est particulièrement adapté au mobilier dont les revêtements ne sont pas amovibles et qui sont dès lors difficilement lavables.

### Consigne d'entretien:

Afin de préserver le plus longtemps possible la qualité exceptionnelle des matériaux, il convient de respecter les consignes de nettoyage. Après l'apparition de la tache, nettoyez celle-ci à l'aide d'un linge en coton en appliquant la quantité nécessaire d'eau afin d'éviter que les saletés ne pénètrent dans le tissu. Le nettoyage répété est susceptible de réduire la couche de protection du matériel. Pour les taches les plus résistantes, vous pouvez ajouter une petite quantité de savon neutre. Nous déclinons toute responsabilité à l'égard des taches agressives, incrustées et non testées.

### Cleaning procedure:

*This specially processed material will give your furniture a more brilliant look. Furthermore, the following stains has been tested on this product by an independent CTL @ licensed laboratory in accordance with DIN EN 12720:*

- |             |             |              |
|-------------|-------------|--------------|
| • Pen       | • Olive oil | • Lipstick   |
| • Mustard   | • Coffee    | • Butter     |
| • Marmelade | • Tea       | • Shoe cream |
| • Ketchup   | • Juice     | • Chocolate  |

### Unique comfort and softness:

*Our Proclean materials are very easy to clean and virtually all stains can be removed without affecting the quality and colour. This material is particularly suitable for furniture whose upholstery cannot be easily removed which makes it difficult to clean.*

### Maintenance instructions:

*In order to maintain the high quality of the material for as long as possible, it is advisable to follow cleaning instructions. Immediately after the stain appears, clean it with a cotton cloth applying a small amount of water as needed to remove the grime without it penetrating deeper into the fabric. Multiple cleaning is likely to reduce the protective layer of the material. For more stubborn stains, you can add a small amount of neutral soap. We are not responsible for aggressive, encrusted, or non-tested stains.*

# Informations techniques

## Technical information

### Non-feu

PVC Classement Non-feu - Normes EN 1021:1/2

*PVC fire resistant rating - Standards EN 1021:1/2*



Méthode de test:

Un banc d'essai est construit à l'aide de mousse et de tissu pour simuler une chaise.

1. Méthode de test - Partie 1: Une cigarette est allumée et placée dans la crevasse du banc de test en contact avec le dossier et le siège. Elle se consume sur toute sa longueur. Le tissu est observé par rapport à la couvaison ou l'inflammation.

2. Méthode de test - Partie 2: Le banc de test composé est à présent testé avec une flamme au butane, qui simule une allumette allumée, dans la crevasse. Après avoir retiré la flamme, le tissu est observé pour voir s'il couve ou s'enflamme dans les 2 min.

3. Résultat: Le matériau de test réussit le test s'il n'y a pas eu d'inflammation ou en cas de zone de combustion limitée.

*Test method:*

*A test rig is constructed using foam and fabric in order to simulate a chair.*

*1. Test method - Part 1: A cigarette is lit and placed in the crevice of the test rig which is in contact with the backrest and the seat. The cigarette is left to smoulder while the reaction of the tissue is being observed during the process of combustion and inflammation.*

*2. Test method - Part 2: The test rig is now tested with a butane flame, which simulates a burning match, placed into the crevice. After removing the flame, the reaction of the tissue is being observed to see if it smoulders or ignites within 2 minutes.*

*3. Result: The test material passes the test if there is no evidence of ignition or if the smouldering site is within the limited acceptable size.*

PVC Classement Non-feu - Crib1- Norme BS 5852-Part1

*PVC fire resistant rating-Crib1-Standard BS 5852-Part 1*

Méthode de test:

Un banc d'essai est construit pour simuler une chaise avec le tissu à tester. Ce banc est soumis à différentes sources d'allumage. Il y a 8 types de sources d'allumage, chacune avec une intensité de chaleur différente. Elles sont classées de 1 à 8, avec une intensité qui double par rapport à la source précédente.

1. Méthode de test - Source 0: Cigarette qui se consume. Une cigarette est placée le long de la crevasse du banc de test et peut brûler sur toute sa longueur.

Si aucune inflammation ou couvaison progressive n'est observée sur la couverture et le matériau intérieur, le test est enregistré comme étant sans allumage et le matériau réussit le test.

2. Résultat: Le matériau de test réussit le test s'il n'y a pas eu d'inflammation ou en cas de zone de combustion limitée.

*Test method:*

*A test rig is constructed in order to simulate a chair with the fabric to be tested. This rig is subjected to different ignition sources. There are 8 types of ignition sources, each with different heat intensity. They are classified from 1 to 8, the intensity doubling the precedent source.*

*1. Test method Source 0: A smouldering cigarette. It is lit and placed in the crevice of the test rig and is left to smoulder. If no combustion or inflammation is observed on the cover and the inner material, the test is recorded as no ignition and the material passes the test.*

*2. Result: The test material passes the test if there is no evidence of ignition or if smouldering site is within the limited acceptable size.*

# Informations techniques

## Technical information

### Stratifié/Méla miné - HPL/Melamine



Méla miné  
Melamine



Stratifié  
HPL

#### Comparatif. Comparison.

##### Résistance à la chaleur:

Le stratifié est plus résistant à la chaleur et sera donc conseillé dans le cas d'une utilisation avec service de plats chauds à table.

##### Heat resistance:

HPL is more resistant to heat and is therefore advised for use with hot plates.

##### Réaction au feu:

Méla miné: M3 Stratifié: M2

##### Reaction to fire:

Melamine: M3 HPL: M2

##### Résistance à l'usure:

Le stratifié comprend une couche de protection, pas le méla miné.

##### Wear resistance:

HPL has a protective coating and melamine does not.

##### Résistance aux coups/chocs:

Le stratifié comprend une couche support en résine, pas le méla miné ; le méla miné est appliqué directement sur le panneau aggloméré.

##### Shock/Impact resistance:

HPL has an additional layer of resin while the melamine is directly applied to the chipboard.

##### Prix:

Le stratifié est sensiblement plus cher que le méla miné.

##### Price:

HPL is significantly more expensive than melamine.

#### Composition Composition

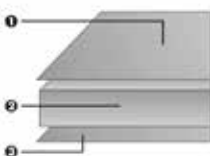

Méla miné  
Melamine

Un film de méla miné est appliqué sur le panneau aggloméré à pression et température élevées. Ce film comprend un papier de base trempé dans de la résine de méla miné. Il peut être imprimé ou non et son poids peut varier. Un papier plus lourd peut absorber plus de résine, de sorte que la couche de méla miné est aussi plus épaisse.

1. Feuille de papier décoratif, imprégnée de résine de méla miné.
2. Panneau aggloméré.
3. Feuille de papier décoratif, imprégnée de résine de méla miné.

A melamine film is pressed on to the chipboard at high pressure and temperature. This film consists of a paper substrate saturated with melamine resin. This paper may or may not be printed and its weight may vary. A heavier paper can absorb more resin, resulting in a thicker melamine layer.

1. Sheet of decorative paper saturated with melamine resin.
2. Chipboard.
3. Sheet of decorative paper saturated with melamine resin.

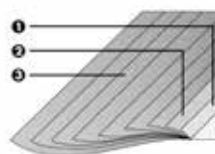

Stratifié  
HPL

Le stratifié à haute pression est constitué d'un empilement de feuilles de papier imprégnées de résines thermodurcissables, qui sont polymérisées sous l'effet d'une pression (8 MPa) et d'une température élevée (150°C).

1. Couche de protection (overlay) imprégnée de résine méla miné (pour tous les décors).
2. Papier décoratif : teinté dans la masse pour les teintes unies ou imprimé pour les décors, imprégné de résine de méla miné.
3. Coeur: un certain nombre de feuilles de papier kraft, imprégnées de résine de phénol.

High-pressure laminate consists of a stack of sheets of paper saturated with thermosetting resin which are polymerized under high pressure (8 MPa) and temperature (150°C).

1. Melamine resin-saturated overlay (for all decors).
2. Decorative paper: mass-dyed for solid colors or printed for decors, saturated with melamine resin.
3. Core: a number of sheets of kraft paper, saturated with phenol resin.



**Piètements Extérieurs**  
Outdoor Table Bases

		Verona 3	Verona 4	Verona Double	Verona 4 Bar	Monza	Monza Bar	Berlin 4	Berlin 2	Berlin 4 Bar
Compact Easy	65x65	-	✓	-	✓	✓	-	✓	-	✓
Topalit Classic	60x60	-	✓	-	✓	✓	✓	✓	-	✓
	Venetto Atacama Cherry 70x70	-	✓	-	✓	✓	-	✓	-	✓
Werzalit Classic	60x60	-	✓	-	✓	✓	✓	✓	-	✓
	Indian Shesham Iceland Oak II Grey Marble Metallo 70x70	-	✓	-	✓	✓	-	✓	-	✓
	Ø60	✓	-	-	-	-	✓	-	-	-
Werzalit Cerclés <i>Werzalit Rimmed</i>  Marrakesh Mermer Black Siyah	Ø60	✓	-	-	-	-	✓	-	-	-
Stratifié Original Collection <i>Original Collection HPL</i>  24mm  Béton Concrete Marmara Minnesota Oak Greige	60x60	-	✓	-	✓	✓	✓	✓	-	✓
	70x70	-	✓	-	✓	✓	-	✓	-	✓
	80x80	-	-	-	-	-	-	✓	-	-
	60x70	-	✓	-	✓	✓	-	✓	-	✓
	110x70	-	-	✓	-	-	-	-	✓	-
	120x70	-	-	✓	-	-	-	-	✓	-
	120x80	-	-	✓	-	-	-	-	✓	-
	Ø70	-	✓	-	✓	✓	✓	✓	-	✓
	Ø120	-	-	-	-	-	-	-	-	-
Stratifié Chêne Halifax <i>Oak Halifax HPL</i>  24mm & 46mm  Chêne Halifax Naturel Chêne Halifax Tabac	60x60	-	✓	-	✓	✓	✓	✓	-	✓
	70x70	-	✓	-	✓	✓	-	✓	-	✓
	80x80	-	-	-	-	-	-	✓	-	-
	60x70	-	✓	-	✓	✓	-	✓	-	✓
	110x70	-	-	✓	-	-	-	-	✓	-
	120x70	-	-	✓	-	-	-	-	✓	-
	120x80	-	-	✓	-	-	-	-	✓	-
	Ø70	-	✓	-	✓	✓	✓	✓	-	✓
	Ø120	-	-	-	-	-	-	-	-	-
Mélaminé <i>Melamine</i>  18mm  Minnesota Oak Chocolat Chêne Halifax Naturel	60x60	-	✓	-	✓	✓	✓	✓	-	✓
	70x70	-	✓	-	✓	✓	-	✓	-	✓
	120x70	-	-	✓	-	-	-	-	✓	-
Chêne Odense <i>Oak Odense</i>  30mm	60x60	-	✓	-	✓	✓	✓	✓	-	✓
	70x70	-	✓	-	✓	✓	-	✓	-	✓
	120x70	-	-	✓	-	-	-	-	✓	-

Piètements Extérieurs Outdoor Table Bases		Empire 3	Empire 4	Empire 4 Bar	Empire 2	Empire Grande	Bistrot 3 H43	Bistrot 3	Bistrot 4	Bistrot 3 Bar
Compact Easy	65x65	-	✓	-	-	-	-	-	✓	-
Topalit Classic Venetto Atacama Cherry	60x60	✓	✓	✓	-	-	✓	✓	✓	✓
	70x70	-	✓	-	-	-	-	-	✓	-
Werzalit Classic Indian Shesham Iceland Oak II Grey Marble Metallo	60x60	✓	✓	✓	-	-	✓	✓	✓	✓
	70x70	-	✓	-	-	-	-	-	✓	-
	Ø60	✓	✓	✓	-	-	✓	✓	✓	✓
Werzalit Cerclés Werzalit Rimmed Marrakesh Mermer Black Siyah	Ø60	✓	✓	✓	-	-	✓	✓	✓	✓
Stratifié Original Collection Original Collection HPL 24mm Béton Concrete Marmara Minnesota Oak Greige	60x60	✓	✓	✓	-	-	✓	✓	✓	✓
	70x70	-	✓	-	-	-	-	-	✓	-
	80x80	-	-	-	-	✓	-	-	-	-
	60x70	-	✓	-	-	-	-	-	✓	-
	110x70	-	-	-	✓	-	-	-	-	-
	120x70	-	-	-	✓	-	-	-	-	-
	120x80	-	-	-	✓	-	-	-	-	-
	Ø70	✓	✓	✓	-	-	-	-	✓	✓
	Ø120	-	-	-	-	✓	-	-	-	-
Stratifié Chêne Halifax Oak Halifax HPL 24mm & 46mm Chêne Halifax Naturel Chêne Halifax Tabac	60x60	✓	✓	✓	-	-	✓	✓	✓	✓
	70x70	-	✓	-	-	-	-	-	✓	-
	80x80	-	-	-	-	✓	-	-	-	-
	60x70	-	✓	-	-	-	-	-	✓	-
	110x70	-	-	-	✓	-	-	-	-	-
	120x70	-	-	-	✓	-	-	-	-	-
	120x80	-	-	-	✓	-	-	-	-	-
	Ø70	✓	✓	✓	-	-	-	-	✓	✓
	Ø120	-	-	-	-	✓	-	-	-	-
Mélaminé Melamine 18mm Minnesota Oak Chocolat Chêne Halifax Naturel	60x60	✓	✓	✓	-	-	✓	✓	✓	✓
	70x70	-	✓	-	-	-	-	-	✓	-
	120x70	-	-	-	✓	-	-	-	-	-
Chêne Odense Oak Odense 30mm	60x60	✓	✓	✓	-	-	✓	✓	✓	✓
	70x70	-	✓	-	-	-	-	-	✓	-
	120x70	-	-	-	✓	-	-	-	-	-

Piètements Intérieurs Indoor Tables Bases		Factory 70	Retro Small	Retro Large	Prato 16	Prato 19	Prato 30	Prato 16 Bar	Prato 30 Bar	Prato 15	Prato 20	Prato 15 Bar	Prato 70
Compact Easy	65x65	-	-	-	✓	-	-	✓	-	-	✓	-	-
Topalit Classic  Venetto Atacama Cherry	60x60	-	-	-	✓	-	-	✓	-	✓	✓	✓	-
	70x70	-	-	-	✓	-	-	✓	-	-	✓	-	-
Werzalit Classic  Indian Shesham Iceland Oak II Grey Marble Metallo	60x60	-	-	-	✓	-	-	✓	-	✓	✓	✓	-
	70x70	-	-	-	✓	-	-	✓	-	-	✓	-	-
	Ø60	-	-	-	✓	-	-	✓	-	✓	✓	✓	-
Werzalit Cerclés <i>Werzalit Rimmed</i>  Marrakesh Mermer Black Siyah	Ø60	-	-	-	✓	-	-	✓	-	✓	✓	✓	-
Stratifié Original Collection <i>Original Collection HPL</i>  24mm  Béton Concrete Marmara Minnesota Oak Greige	60x60	-	-	-	✓	-	-	✓	-	✓	✓	✓	-
	70x70	✓	-	-	✓	-	-	✓	-	-	✓	-	-
	80x80	-	-	-	-	-	-	-	-	-	✓	-	✓
	60x70	-	✓	-	✓	✓	-	✓	-	-	✓	-	-
	110x70	-	-	✓	-	✓	✓	-	✓	-	-	-	-
	120x70	-	-	-	-	-	✓	-	✓	-	-	-	-
	120x80	-	-	-	-	-	✓	-	✓	-	-	-	-
	Ø70	-	-	-	✓	-	-	✓	-	✓	✓	✓	✓
	Ø120	-	-	-	-	-	-	-	-	-	-	-	✓
Stratifié Chêne Halifax <i>Oak Halifax HPL</i>  24mm & 46mm  Chêne Halifax Naturel Chêne Halifax Tabac	60x60	-	-	-	✓	-	-	✓	-	✓	✓	✓	-
	70x70	✓	-	-	✓	-	-	✓	-	-	✓	-	-
	80x80	-	-	-	-	-	-	-	-	-	✓	-	✓
	60x70	-	✓	-	✓	✓	-	✓	-	-	✓	-	-
	110x70	-	-	✓	-	✓	✓	-	✓	-	-	-	-
	120x70	-	-	-	-	-	✓	-	✓	-	-	-	-
	120x80	-	-	-	-	-	✓	-	✓	-	-	-	-
	Ø70	-	-	-	✓	-	-	✓	-	✓	✓	✓	✓
	Ø120	-	-	-	-	-	-	-	-	-	-	-	✓
Mélaminé <i>Melamine</i>  18mm  Minnesota Oak Chocolat Chêne Halifax Naturel	60x60	-	-	-	✓	-	-	✓	-	✓	✓	✓	-
	70x70	✓	-	-	✓	-	-	✓	-	-	✓	-	-
	120x70	-	-	-	-	-	✓	-	✓	-	-	-	-
Chêne Odense <i>Oak Odense</i>  30mm	60x60	-	-	-	✓	-	-	✓	-	✓	✓	✓	-
	70x70	-	-	-	✓	-	-	✓	-	-	✓	-	-
	120x70	-	-	-	-	-	✓	-	✓	-	-	-	-

Piètements Intérieurs Indoor Table Bases		Rome 05	Rome 06	Rome 05 Bar	Rome 12	Rome 13	Rome 12 Bar	Sydney 4	Sydney 2	Sydney 4 Bar
Compact Easy	65x65	-	✓	-	✓	-	✓	✓	-	✓
Topalit Classic Venetto Atacama Cherry	60x60	✓	-	✓	✓	-	✓	✓	-	✓
	70x70	-	✓	-	✓	-	✓	✓	-	✓
Werzalit Classic Indian Shesham Iceland Oak II Grey Marble Metallo	60x60	✓	-	✓	✓	-	✓	✓	-	✓
	70x70	-	✓	-	✓	-	✓	✓	-	✓
	Ø60	✓	-	✓	✓	-	✓	✓	-	✓
Werzalit Cerclés Werzalit Rimmed Marrakesh Mermer Black Siyah	Ø60	✓	-	✓	✓	-	✓	✓	-	✓
Stratifié Original Collection Original Collection HPL 24mm Béton Concrete Marmara Minnesota Oak Greige	60x60	✓	-	✓	✓	-	✓	✓	-	✓
	70x70	-	✓	-	✓	-	✓	✓	-	✓
	80x80	-	✓	-	✓	-	-	-	-	-
	60x70	-	✓	-	✓	✓	✓	✓	-	✓
	110x70	-	-	-	-	✓	-	-	✓	-
	120x70	-	-	-	-	✓	-	-	✓	-
	120x80	-	-	-	-	✓	-	-	✓	-
	Ø70	✓	✓	✓	✓	✓	✓	✓	-	✓
	Ø120	-	✓	-	-	-	-	-	-	-
Stratifié Chêne Halifax Oak Halifax HPL 24mm & 46mm Chêne Halifax Naturel Chêne Halifax Tabac	60x60	✓	-	✓	✓	-	✓	✓	-	✓
	70x70	-	✓	-	✓	-	✓	✓	-	✓
	80x80	-	✓	-	✓	-	-	-	-	-
	60x70	-	✓	-	✓	✓	✓	✓	-	✓
	110x70	-	-	-	-	✓	-	-	✓	-
	120x70	-	-	-	-	✓	-	-	✓	-
	120x80	-	-	-	-	✓	-	-	✓	-
	Ø70	✓	✓	✓	✓	✓	✓	✓	-	✓
	Ø120	-	✓	-	-	-	-	-	-	-
Mélaminé Melamine 18mm Minnesota Oak Chocolat Chêne Halifax Naturel	60x60	✓	-	✓	✓	-	✓	✓	-	✓
	70x70	-	✓	-	✓	-	✓	✓	-	✓
	120x70	-	-	-	-	✓	-	-	✓	-
Chêne Odense Oak Odense 30mm	60x60	✓	-	✓	✓	-	✓	✓	-	✓
	70x70	-	✓	-	✓	-	✓	✓	-	✓
	120x70	-	-	-	-	✓	-	-	✓	-

# Pièces détachées

## *Spare parts*

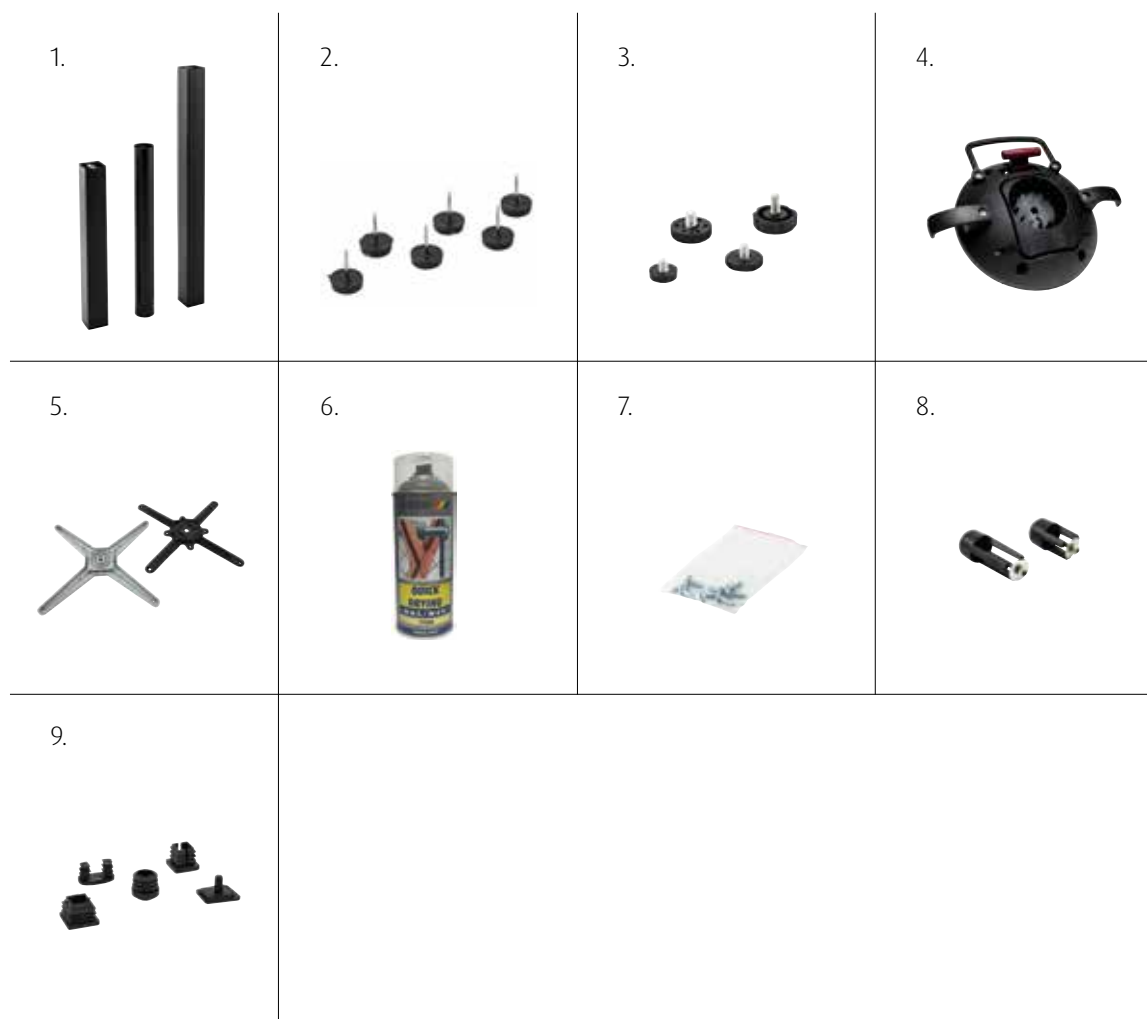

1. Tubes métalliques pour piètements intérieurs. *Metal tubes for indoor table bases.* 2. Patins en nylon à clouer pour mobilier en bois. *Nylon gliders for wooden furniture.* 3. Vérins de réglage pour piètements. *Table bases plugs.* 4. Verona Système basculant. *Verona fliptop system.* 5. Croix de fixation pour piètements. *Cross for table bases.* 6. Bombe aérosol de couleur pour la gamme Bastille & Pigalle - 400ml. *Colour spray can for the Bastille & Pigalle range - 400ml.* 7. Vis de montage pour plateaux de table. *Screws for tables tops.* 8. Empire éléments de fixation. *Assembly parts for the Empire table.* 9. Bouchons PVC pour mobilier intérieur et extérieur. *PVC plugs for outdoor and indoor furniture.*

























## Vidéos de montage

























### *Assembly videos*



Retrouvez nos vidéos de montage via ce QR code.  
*Find our assembly videos via this QR code.*



 <p>New</p> <p>Simone p08</p>	 <p>New</p> <p>René p10</p>	 <p>New</p> <p>Auguste p11</p>	 <p>New</p> <p>Mélina p14</p>	 <p>New</p> <p>Sandra p16</p>
 <p>New</p> <p>Noëlia p18</p>	 <p>New</p> <p>Zoé p20</p>	 <p>New</p> <p>Ralph p22</p>	 <p>New</p> <p>Paulette p24</p>	 <p>New</p> <p>Colette p26</p>
 <p>Adèle p28</p>	 <p>Victoire Bst p30</p>	 <p>New</p> <p>Mikka p32</p>	 <p>New</p> <p>Olaf p34</p>	 <p>New</p> <p>Jacob p36</p>
 <p>New</p> <p>Kyle p38</p>	 <p>New</p> <p>Wendy p40</p>	 <p>Maurice p42</p>	 <p>Maurice Bst p44</p>	 <p>New</p> <p>College p46</p>
 <p>New</p> <p>Montreal p48</p>	 <p>Stanley p50</p>	 <p>Stanley Bst p52</p>	 <p>Brixton p54</p>	 <p>Soho p56</p>

				
Alex p58	Barossa p60	Peak p62	Condor p64	Pickup p66
				
Splash p68	Alicia p70	Capri p72	Cuba p74	Cuba double p76
 <span style="border: 1px solid black; border-radius: 50%; padding: 2px;">New</span>				
Kate p78	Budapest p80	Budapest Bst p82	Dimitri p84	Dimitri Bst p86
				
Brooklyn p88	Brooklyn Bst p90	Pub p92	Pub Bst p94	Sofia p96
				
Sofia Bst p98	Maurice Velours p100	Maurice Velours Bst p102	Emile p104	Alfonse p106





Oscar Bst p108



Lautrec S p110



Arnold p112



Willy p114



Floriane II p116



Floriane Bst II p118



Lena p120



Madison p122



Clinton p124



Clinton Bst p126



Maryne p128



Jolyne p130



Ellen p132



Factory p134



Retro Small p135



Retro Large p135



Bistrot 3 H43 p136



Bistrot 3 p136



Bistrot 4 p137



Bistrot 3 Bar p134



Prato 16 p138



Prato 19 p138



Prato 30 p138



Prato 16 Bar p139

				
Prato 30 Bar p139	Prato 15 p140	Prato 20 p140	Prato 15 Bar p141	Prato 70 p141
				
Rome 05 p142	Rome 06 p142	Rome 05 Bar p142	Rome 12 p143	Rome 13 p143
				
Rome 12 Bar p143	Sydney 4 p144	Sydney Double p144	Sydney 4 Bar p145	Stratifié Original p146
				
Stratifié Chêne Halifax p148	Mélaminé p150	Odense p152	William p154	Jacky p156



Orléans p160



Rochelle p162



Brest p164



Sorbonne p166



Madeleine p168



Passy p170



Savana p172



Amsterdam p174



Breda p176



Fiori p178



Fiori F p180



Concorde p182



Saint-Tropez p184



Seine p186



Louvre p188



Dauphine p190



Paris p192



Montmartre p194



Drouot p196



Trocadero p198



Bastille p200



Bastille Bst p202



Pigalle p204



Pack Bastille & Pigalle p206



Penelope p208



Ulysse p210



Tom Bar 75 p212



Monna p214



Sky Pro p216



Maya p218



Maya Bar 75 p220



Fado p222



Atlantic p224



Marcel p226



Marcel XL p228



Marcel Bar 75 p230



Daytona p232



Panama p234



Jamaica p236



Jamaica F p238



Jamaica Bst p240



Kys p242



Kys Bar p244



Pack Sky Pro & Kys p246



Pack Tom Bar 75 & Kys Bar p247



Pack Maya & Kys

p248



Pack Maya Bar 75 & Kys Bar

p249



Eolo Pureti

p250



Canto

p252



Verona 3

p254



Verona Double

p254



Verona 4

p255



Verona 4 Bar

p255



Monza

p256



Monza Bar

p256



Berlin 2

p258



Berlin 4

p258



Berlin 4 Bar

p259



Empire 3

p260



Empire 4

p260



Empire 4 Bar

p260



Empire 2

p261



Empire Grande

p261



Bistrot 3 H43

p262



Bistrot 3

p262



Bistrot 4

p263



Bistrot 3 Bar

p263



Compact Easy

p264



Topalit Classic p266



Werzalit Classic p268



Werzalit Cerclé p270

Réception - Catering



Daisy p274



Tiffany p276



Napoléon p278



XL 180 p280



Cocktail 80 p281



Osaka p282



Pack Cocktail 80 & Osaka p283



**RMBPROJECTS**